

GREY FIKA 23L MICROWAVE

Product Instructions

Product No. 2000300

vonshef

Let's get started!

Visit our product hub for useful tips and tricks on getting the most out of your new product.

SCAN ME



Components

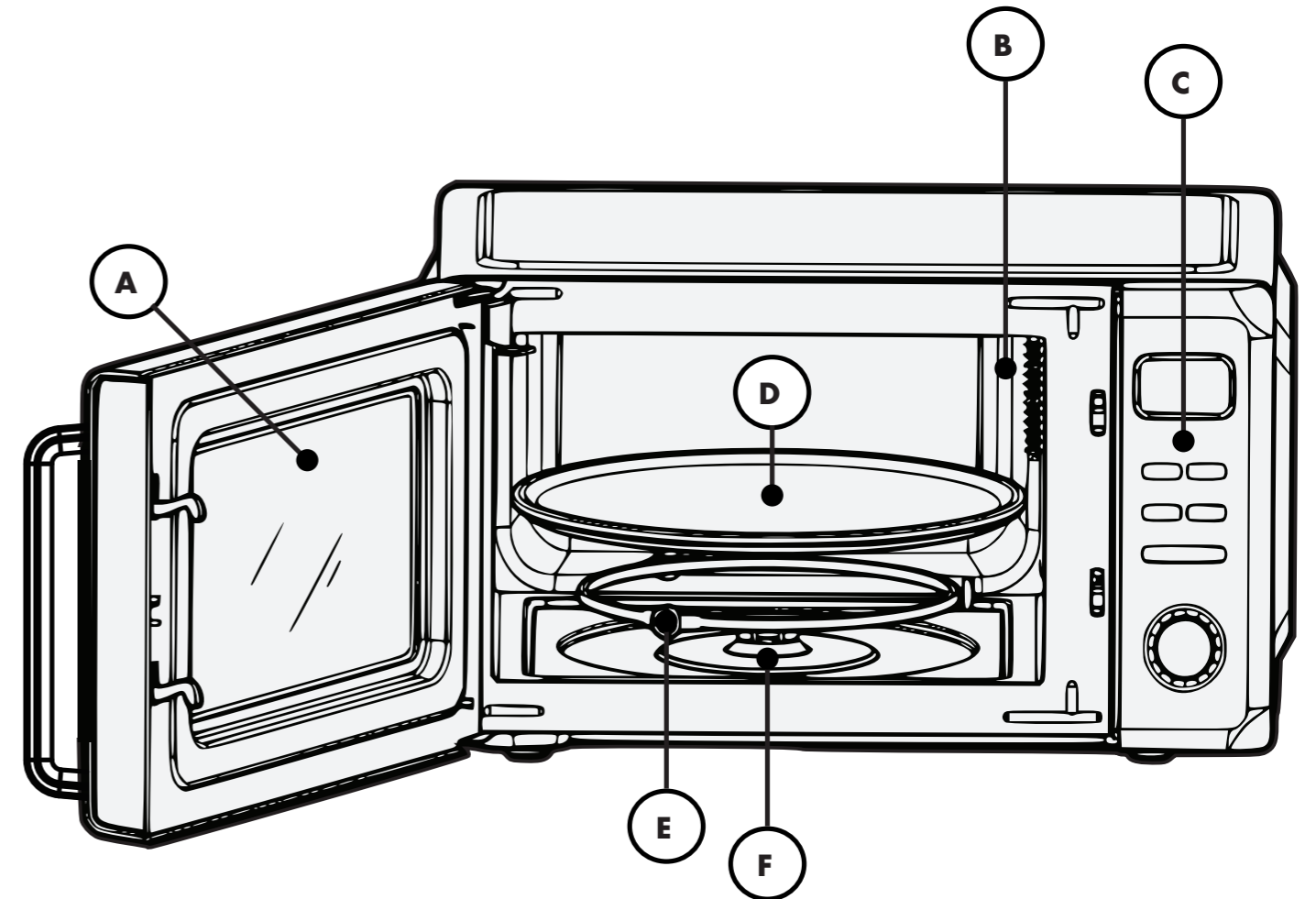

Need further help?
support@vonhaus.com

See our full range at
www.vonhaus.com

A. Oven Window
B. Wave Guide (Do not Remove)
C. Control Panel

D. Glass Tray
E. Roller Ring
F. Shaft

Control Panel

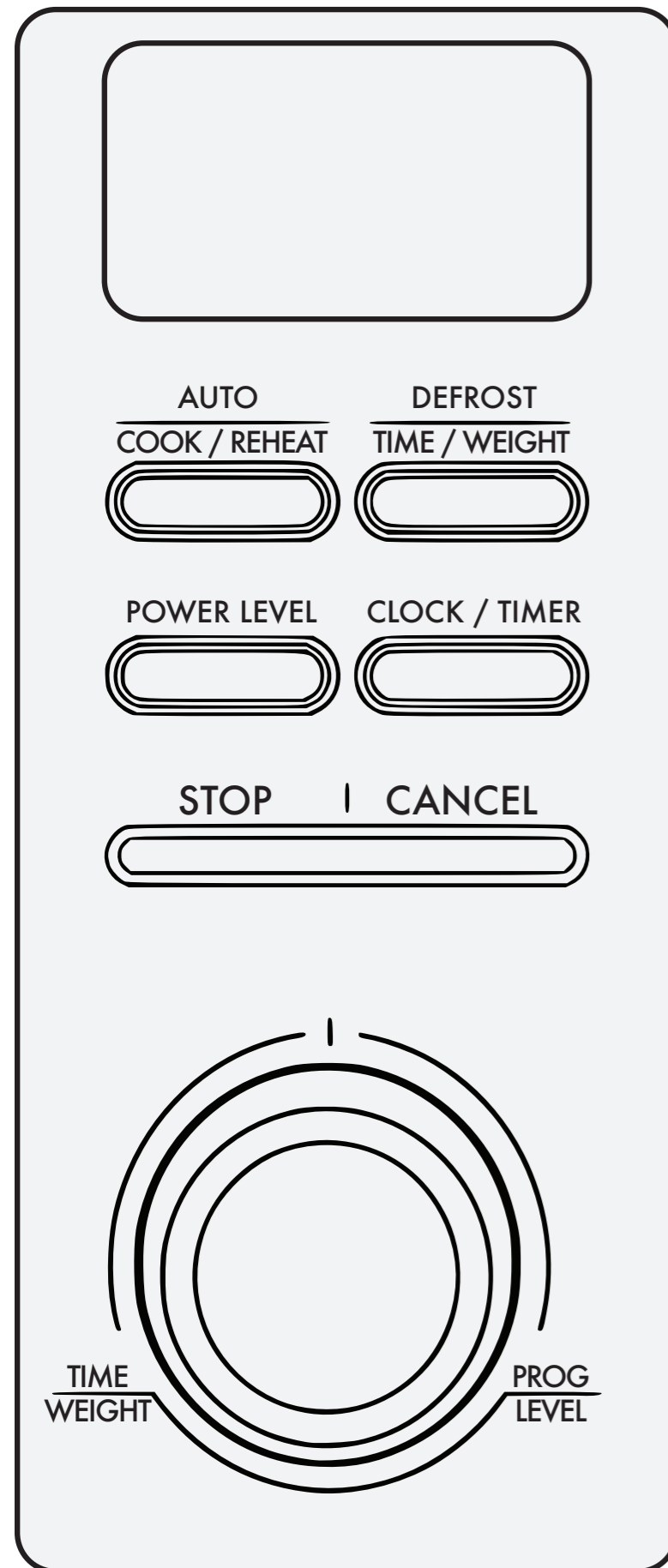

MENU ACTION SCREEN

Time, power and indicators are displayed.

AUTO/COOK/REHEAT

Press to set auto cooking and reheating programs.

DEFROST/TIME/WEIGHT

Press once to defrost food based on time.
Press twice to defrost food based on weight.

POWER LEVEL

Press to select cooking power level.

CLOCK/TIMER

Press to set clock time.
Press to set timer function.

STOP/CANCEL

Press once to temporarily stop cooking, or twice to cancel cooking altogether.

TIME/WEIGHT/PROG/LEVEL (dial)

Turn to set time and food weight.

START/+30 SEC (the dial)

Press the dial to start cooking programs.
Press to set express cooking program.

Information

General Operation

Power On: When the microwave is first plugged in, a beep will sound, and the display will show the clock icon and "12:00" (with the colon flashing).

Standby Mode: During setup, if there is no operation within 30 seconds, the system will automatically revert to standby mode.

Pausing & Cancelling:

- Press the **STOP/CANCEL** button once during cooking to pause the programme; press the **START/+30 SEC** button to resume.
- Press the **STOP/CANCEL** button twice to cancel the programme completely.

Completion: When cooking finishes, the display will show "End" and the buzzer will beep until you press a button or open the door.

Button Sounds: A valid button press produces one beep. If an invalid button is pressed, the buzzer will beep twice.

Clock & Timer Settings

Setting the Clock

You can set the time in a 12-hour or 24-hour format.

1. In standby mode, press and hold the **CLOCK/TIMER** button for 3 seconds to enter clock setup. Press the button again to toggle between the 24-hour and 12-hour cycle.
2. Turn the **TIME/WEIGHT/PROG/LEVEL** dial to select the hour figure.
3. Press **CLOCK/TIMER** or **START/+30 SEC** once to confirm.

4. Turn the dial to select the minute figure.
5. Press **CLOCK/TIMER** or **START/+30 SEC** to finish.

Note: You can check the time during cooking by pressing and holding the **CLOCK/TIMER** button for 3 seconds.

Timer

1. Press the **CLOCK/TIMER** button once (in standby or during cooking).
2. Turn the dial to set the desired time (10 seconds to 95 minutes).
3. Press **START/+30 SEC** to confirm and start the countdown.

Note: When the countdown ends, the buzzer will beep. You can check the timer time by clicking the **CLOCK/TIMER** button once and cancel the timer by clicking the **STOP/CANCEL** button.

Manual Cooking

Express Cooking

Use this for quick heating at 100% power.

- **Method 1:** Press the **START/+30 SEC** button in standby mode to cook for 30 seconds. Each additional press adds 30 seconds (up to 30 minutes).
- **Method 2:** Turn the dial in standby mode to set a specific time, then press **START/+30 SEC** to begin.

Microwave Cooking

Customise the power and time.

1. Press the **POWER LEVEL** button repeatedly to select the power percentage.
2. Turn the dial to set the cooking time (10 seconds to 95 minutes).
3. Press **START/+30 SEC** to start.

Information

Defrosting

Time Defrost

1. Press the **DEFROST/TIME/WEIGHT** button once.
2. Turn the dial to set the desired defrosting time (10 seconds to 95 minutes).
3. Press **START/+30 SEC** to begin.

Weight Defrost

The microwave automatically sets the time and power based on the food type and weight.

1. Press **DEFROST/TIME/WEIGHT** twice.
2. Turn the dial to select the food code (see table below).
3. Press **START/+30 SEC** to confirm.
4. Turn the dial to select the weight.
5. Press **START/+30 SEC** to start.

Weight Defrost Codes and Ranges

- Code **DEF1** (Meat): Suitable for weights between 100 g and 1800 g.
- Code **DEF2** (Poultry): Suitable for weights between 100 g and 1800 g.
- Code **DEF3** (Seafood): Suitable for weights between 100 g and 900 g.

Note: The system will pause and beep during defrosting to remind you to turn the food over. Turn the food, then press Start to resume.

Auto Cook Menus

No manual settings required—select the food type and weight.

1. Press **AUTO COOK/REHEAT** once (Display shows “**AC-1**”).
2. Turn the dial to select the desired menu code (**AC-1 to AC-7**).
3. Press **START/+30 SEC** to confirm.
4. Turn the dial to set the weight or number of servings.
5. Press **START/+30 SEC** to start.

Auto Cook Guide

- AC-1: Popcorn (100 g)

For popcorn (code AC-1), you can turn the **TIME/WEIGHT/PROG/LEVEL** dial to change the cooking time before pressing the **START/+30 SEC** button; the setting can be adjusted from 10 seconds up to 5 minutes.

- AC-2: Potato (230±10 g/serving, 1-2 servings)
- AC-3: Fresh Vegetable (200-600 g)
- AC-4: Frozen Vegetable (200-600 g)
- AC-5: Oatmeal (1-3 servings)
- AC-6: Corn On The Cob (1-4 roots)
- AC-7: Rice (150-600 g)

The final result of auto cooking depends on voltage fluctuations, the size and shape of the food, how well cooked you prefer it, and how you place it in the oven.

If the result is not satisfactory, you should slightly increase or decrease the cooking time to suit your preference.

Information

Auto Reheat Menus

1. Press **AUTO COOK/REHEAT** twice (the display will show “AH-1”).
2. Turn the dial to select the specific menu code (AH-1 to AH-10).
3. Press **START/+30 SEC** to confirm your selection.
4. Turn the dial to set the weight of the food or the number of servings
5. Press **START/+30 SEC** to begin reheating.

Auto Reheat Guide

- AH-1: Beverage (1–3 cups)
- AH-2: Dinner Plate (200–600 g)
- AH-3: Frozen Entrée (200–600 g)
- AH-4: Pizza (1–2 slices)
- AH-5: Soup/Sauce (200–600 g)
- AH-6: Chilli (200–600 g)
- AH-7: Pasta (200–600 g)
- AH-8: Macaroni Cheese (200–600 g)
- AH-9: Mashed Potatoes (200–600 g)
- AH-10: Rice (200–600 g)

Note: Results may vary depending on food shape and voltage. Adjust the time manually if the result is not to your satisfaction.

Information

Child Lock

This feature prevents unsupervised operation by children.

- **To Activate:** In standby mode, if there is no operation within one minute, the oven will automatically enter Child Lock mode. The lock indicator light will turn on.
- **To Cancel:** Simply open or close the oven door. The lock indicator light will turn off, and the programme is cancelled.

Stuck Button Protection

If any button on the control panel becomes stuck for more than one minute, the programme will stop immediately. The display will show **"FAIL"** and the system will beep.

- If the button remains stuck, the beep will sound every minute.
- All buttons are disabled during this time.
- Once the issue is resolved, press the **STOP/CANCEL** button to return to standby mode.

Cleaning and Care

Power Off: Always turn off the oven and unplug the power cord from the wall socket before cleaning.

Interior Cleaning: Keep the inside of the oven clean. Wipe away food splatters or spilled liquids with a damp cloth. You may use a mild detergent if the oven is very dirty. Avoid harsh sprays or abrasive cleaners, as they may stain, streak, or dull the door surface.

Exterior Cleaning: Clean the outside with a damp cloth. To prevent damage to internal components, do not allow water to seep into the ventilation openings.

Door Maintenance: Frequently wipe the door, window, door seals, and adjacent parts with a damp cloth to remove spills or splatters. Do not use abrasive cleaners.

Control Panel: Do not allow the control panel to become wet. Clean it with a soft, slightly damp cloth. Leave the oven door open while cleaning the panel to prevent accidental activation.

Condensation: If steam accumulates inside or around the outside of the oven door, wipe it with a soft cloth. This is normal when operating the microwave under high humidity conditions.

Glass Tray: Occasionally remove the glass tray for cleaning. Wash it in warm, soapy water or in a dishwasher.

Roller Ring & Oven Floor: Clean the roller ring and oven floor regularly to prevent excessive noise. Wipe the bottom surface with a mild detergent. The roller ring can be washed in mild, soapy water or a dishwasher. Ensure it is replaced in the correct position.

Removing Odours: Place a microwave-safe bowl containing a cup of water and the juice and skin of one lemon into the oven. Microwave for 5 minutes, then wipe the interior thoroughly and dry with a soft cloth.

Light Bulb: If the internal light bulb fails, please contact customer service for a replacement.

General Maintenance: Clean the oven regularly and remove any food deposits. Failure to maintain the oven in a clean condition could lead to surface deterioration, which may adversely affect the lifespan of the unit and potentially cause a hazardous situation.

Usage & Safety



Please read all instructions carefully before use and retain for future reference.



CAUTION: Hot surfaces.



Keep all electrical components dry at all times. Water and electricity create serious safety hazards that can result in injury or death.



Do not use outdoors

Safety

Important Safety Notice

This product is **not suitable for use by children** or by individuals with **physical, sensory, or mental impairments** that may limit their ability to operate the equipment safely, **unless** they have been given supervision or instruction concerning the safe use of the product by a person responsible for their safety.

Precautions to Avoid Possible Exposure to Excessive Microwave Energy

1. Do not attempt to operate this oven with the door open, as open-door operation can result in harmful exposure to microwave energy. It is important not to defeat or tamper with the safety interlocks.
2. Do not place any object between the oven front face and the door, or allow soil or cleaner residue to accumulate on sealing surfaces.
3. Do not operate the oven if it is damaged. It is particularly important that the oven door closes properly and that there is no damage to the:
 - Door (bent)
 - Hinges and latches (broken or loosened)
 - Door seals and sealing surfaces
4. The oven should not be adjusted or repaired by anyone except properly qualified service personnel.

Microwave Safety

Door Operation: Do not attempt to operate this oven with the door open, as this can result in harmful exposure to microwave energy. It is vital not to defeat or tamper with the safety interlocks.

Obstructions: Do not place any object between the oven front face and the door, or allow soil or cleaning residue to accumulate on the sealing surfaces.

Cables and Plugs

Power Supply: Ensure your electricity supply matches the rating plate. This product should only be used as rated. Ideally, the socket outlet should be protected by a Residual Current Device (RCD).

Damaged Cables: Do not use the appliance with a damaged cable or plug. If the supply cable is damaged, it must be replaced by a qualified engineer or authorised service agent to avoid hazards.

Extension Cables: The use of an extension cable is not recommended.

Handling: Do not handle the plug or appliance with wet hands.

Positioning:

- Keep the cable away from heated surfaces.
- Do not let the cable hang over the edge of a table or worktop where it could be pulled inadvertently by children or pets.
- Do not pull the cable around sharp edges or corners.
- Do not leave the appliance unattended when plugged in.

Unplugging:

- Turn off all controls before unplugging.
- Unplug from the outlet when not in use.
- Grasp the plug, not the cable, to unplug.
- Always unplug before performing maintenance, connecting/disconnecting attachments, or changing accessories.

Storage: Ensure the cable is stored safely to prevent trip hazards.

Safety

Risk of Personal Injury

Placement: Always locate your appliance away from the edge of the worktop on a firm, flat, heat-resistant surface with sufficient space on all sides. Do not use outdoors or near heat sources.

Ventilation: Do not insert objects into openings or cover the appliance.

Prohibited Materials: Do not place cardboard, plastics, or paper inside or on the appliance unless stated in the instructions.

Combustibles: Do not use the appliance near any combustible surfaces.

Cookware: Only use suitable cookware where applicable.

Hot Surfaces:

- Take care not to touch any surfaces that may get hot during use.
- Be aware that surfaces may remain hot for a period after use.

Operation

Never operate the appliance when empty.

Do not overload or overfill the appliance.

Do not lift or move the appliance whilst in use.

Do not operate continuously for periods longer than those marked on the product or indicated in the instructions.

First Use: When using for the first time, the appliance may give off a 'new' smell or vapour. This will dissipate after a few uses.

Cleaning Prep: Ensure the appliance is switched off and unplugged before changing accessories or cleaning.

Information

Customer Service

If you are having difficulty using this product and require support, please contact support@vonhaus.com

Warranty

To register your product and find out if you qualify for a free extended warranty please go to www.vonhaus.com/warranty

Please retain a proof of purchase receipt or statement as proof of the purchase date.

The warranty only applies if the product is used solely in the manner indicated in the warnings page of this manual, and all other instructions have been followed accurately.

Any abuse of the product or the manner in which it is used will invalidate the warranty.

Returns

Returned goods will not be accepted unless re-packaged in its original packaging and accompanied by a relevant and completed returns form. This does not affect your statutory rights.

No rights are given under this warranty to a person acquiring the appliance second-hand or for commercial or communal use.

Copyright

All material in this instruction manual are copyrighted by DOMU Brands.

Any unauthorised use may violate worldwide copyright, trademark, and other laws.

Thank You

Thank you for purchasing your product/appliance.

Should you require assistance with your purchase, please contact us at support@vonhaus.com

Vonhaus is a registered trademark of DOMU Brands Ltd.

Made in China for DOMU Brands Ltd.
Unit 30, Stakehill Industrial Estate
Middleton, Manchester, M24 2RW

EU Authorised Representative

Authorised Representative Service
77 Camden Street Lower
Dublin, D02 XE80
Ireland

Let's get started!

Visit our product hub for useful tips and tricks on getting the most out of your new product.

SCAN ME

