

CREAM MICROWAVE, KETTLE & 2 SLICE TOASTER BUNDLE

Product Instructions

Product No. 2000324

vonshef

Let's get started!

Visit our product hub for useful tips and tricks on getting the most out of your new product.

SCAN ME

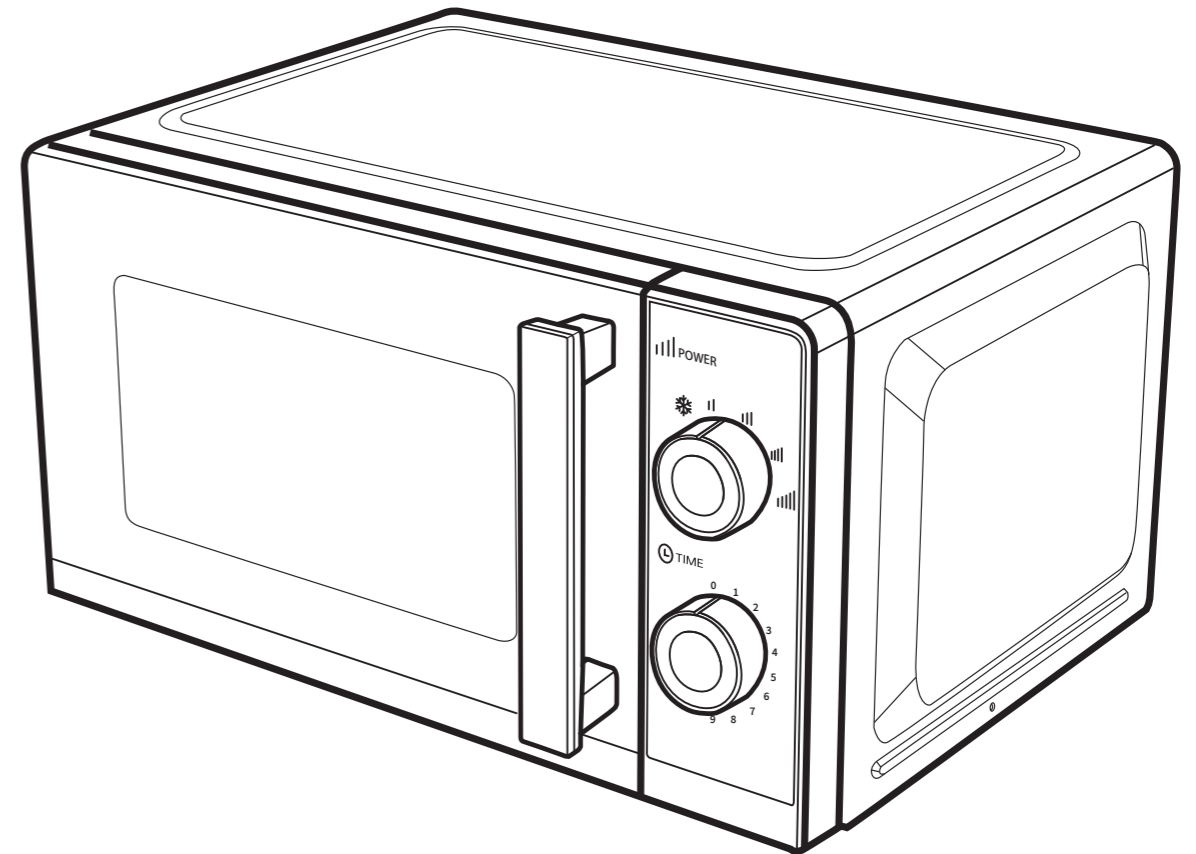

Need further help?
support@vonhaus.com

See our full range at
www.vonhaus.com

CREAM FIKA MICROWAVE

Product Instructions

Product No. 2000324

vonshef

Components

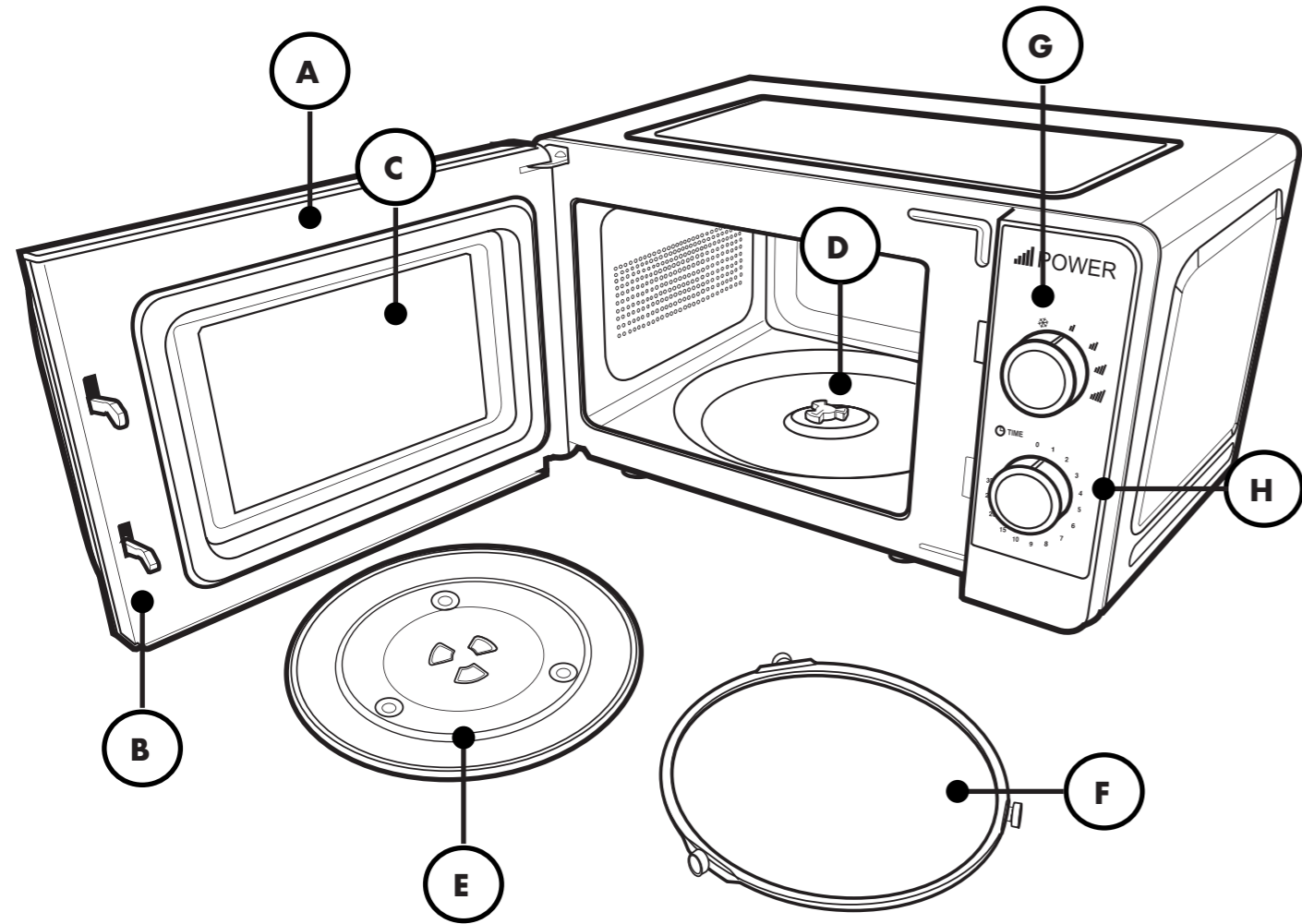

- A. Door
- B. Door Locks
- C. Viewing Window
- D. Rotating Axis
- E. Turntable

- F. Rotator Ring
- G. Power Dial
- H. Timer Dial

Part Names

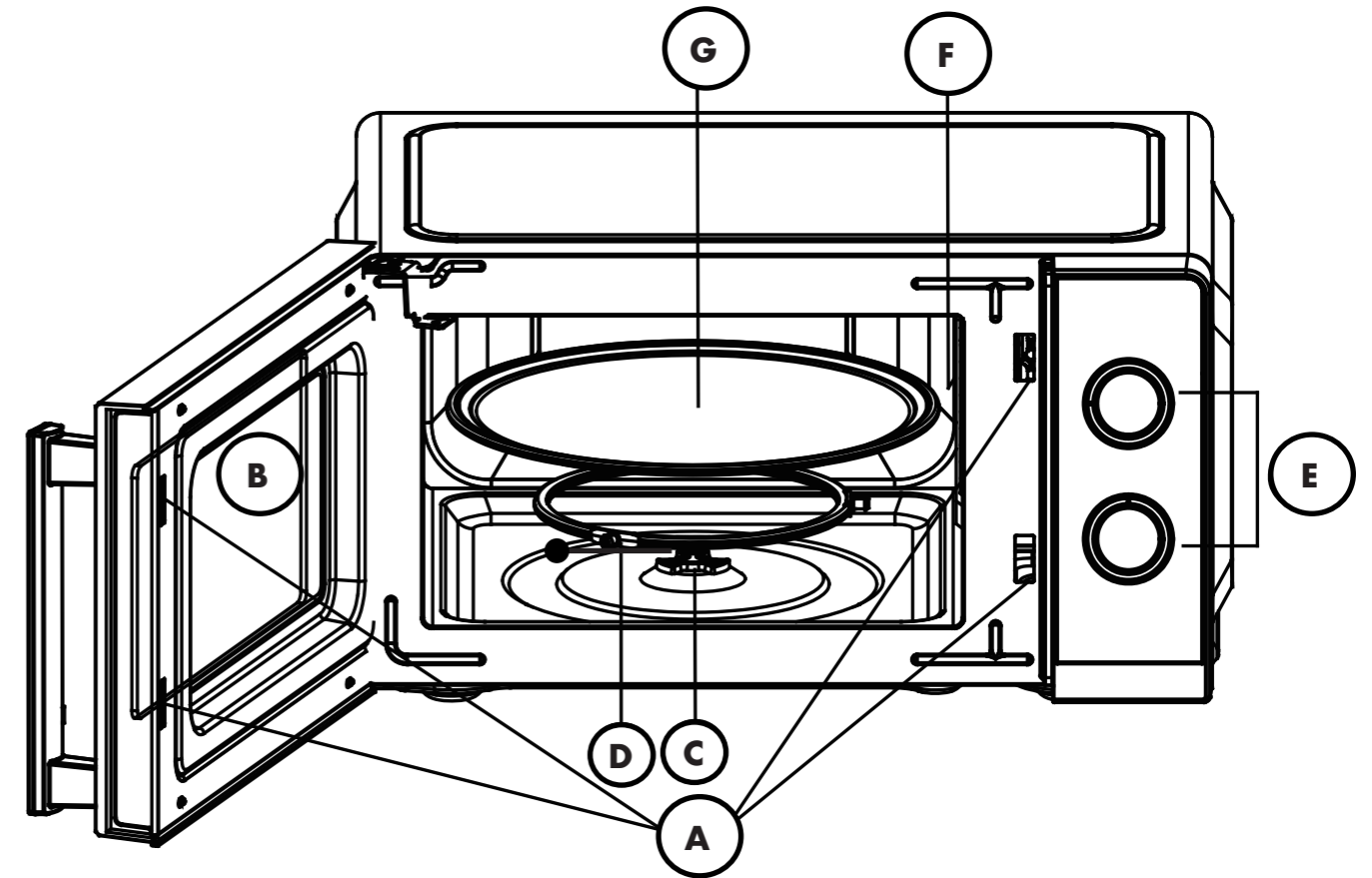

- A. Door Safety Lock System
- B. Oven Window
- C. Shaft
- D. Roller Ring
- E. Control Panel

- F. Wave Guide (Do Not Remove the Mica Plate Covering the Wave Guide)
- G. Glass Tray

Control Panel

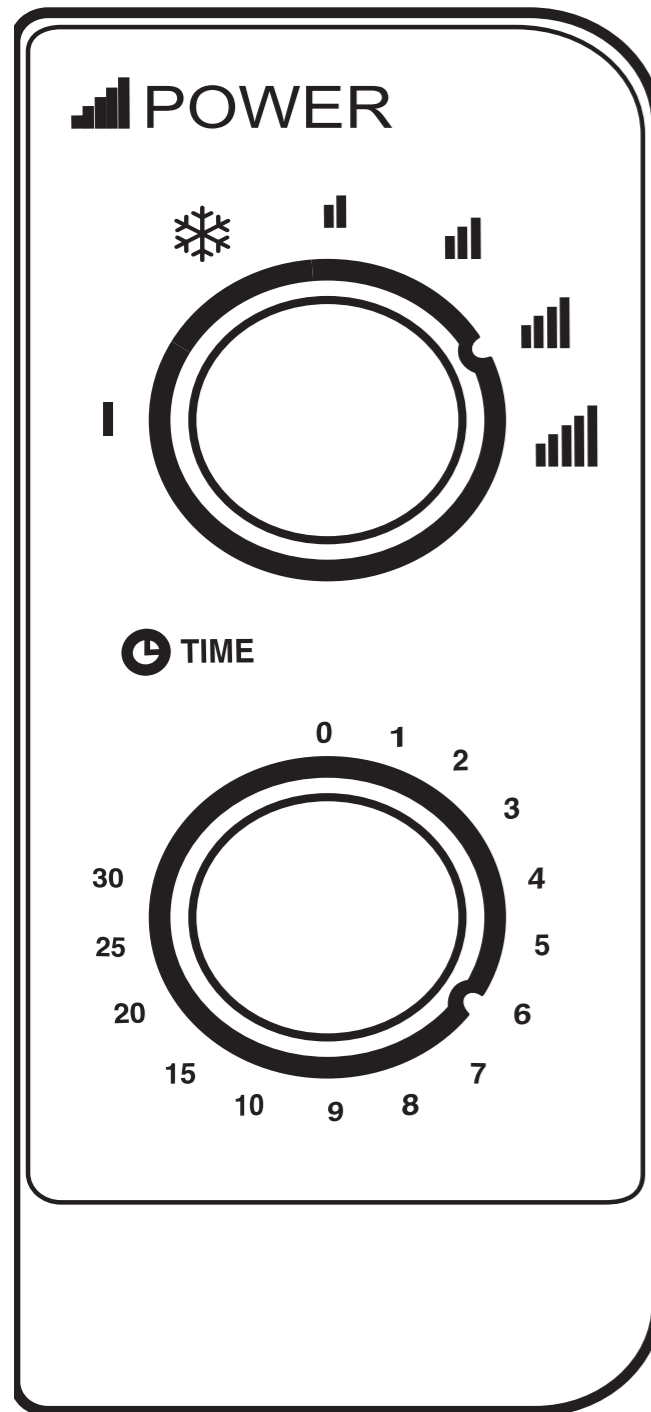

Power Dial

The power dial has six settings:

- **Low** — 20% output. Best for keeping food warm.
- **Defrost** — 42% output. Suitable for defrosting frozen food.
- **M.Low** — 52% output. Best for drinks or soups.
- **Med** — 73% output. Slow cooking.
- **M.High** — 88% output. Normal cooking.
- **High** — 100% output. Fast cooking.

Timer Dial

The timer can be set to a maximum of 30 minutes. Once set, the dial will automatically rotate back to the 0 position and a bell will sound to indicate that cooking has finished.

Operation

To start a cooking session:

1. Place food in the oven and close the door.
2. Turn the power dial to select a power level.
3. Use the timer dial to set a cooking time.
The oven will begin cooking immediately.

Note: When setting a time of less than 2 minutes, turn the timer past 2 minutes first, then return to the correct time.

Caution: Always return the timer to the zero position if food is removed before the set cooking time has elapsed, or when the oven is not in use. To stop the oven during cooking, press the door release button or open the door by the handle.

Cleaning

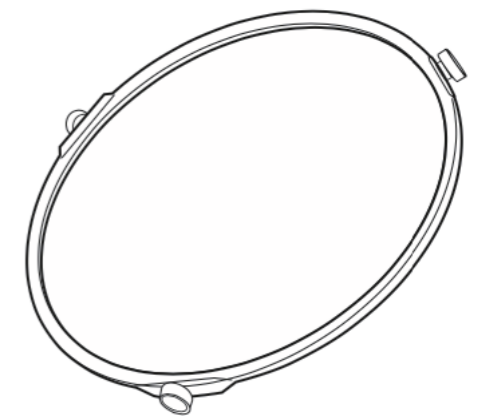
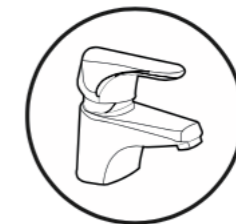
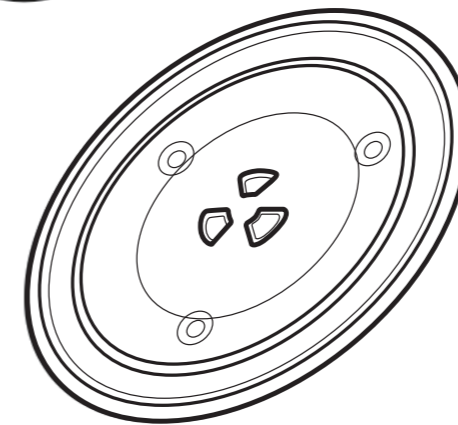
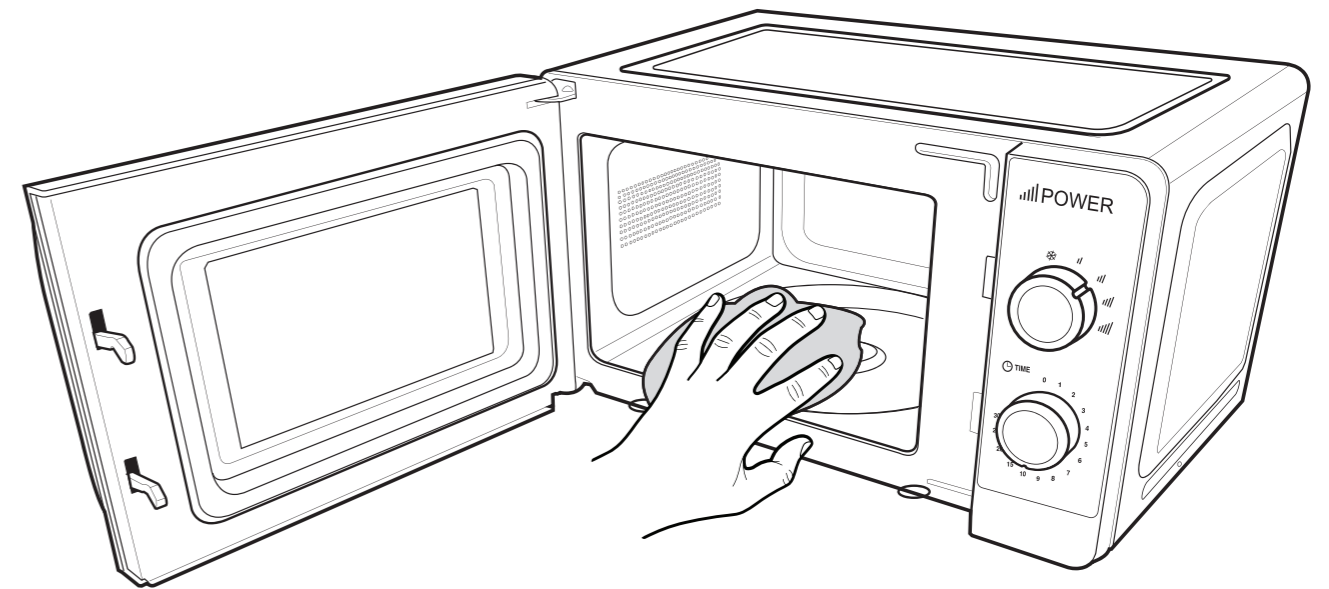

Information

Important Safety Notice

This product is not suitable for use by children or by individuals with physical, sensory, or mental impairments that may limit their ability to operate the equipment safely, unless they have been given supervision or instruction concerning the safe use of the product by a person responsible for their safety.

Improper use may result in serious injury. Always ensure the operator is capable of understanding and following all safety instructions provided in this manual.

Surfaces become very hot during use.

Cookware Suitability

Heat-resistant glass — suitable

Non heat-resistant glass — not suitable

Heat-resistant ceramics — suitable

Microwave-safe plastic — suitable

Kitchen paper — suitable

Metal tray — not suitable

Metal rack — not suitable

Aluminium foil and foil containers — not suitable

Utensils Guide

Only use utensils suitable for microwave ovens. Metal containers are not permitted unless the manufacturer has specified they are suitable for microwave use.

Do not use metal utensils or dishes with metallic trim.

Do not use recycled paper products in the microwave, as they may contain metal fragments that can cause sparking or fire.

Round or oval dishes are preferable to square or oblong ones, as food in corners tends to overcook.

Narrow strips of aluminium foil may be used to shield areas prone to overcooking. Take care not to use too much, and maintain a gap of at least 2.5cm between the foil and the oven cavity walls.

Cleaning and care

1. Turn off the oven and unplug from the wall socket before cleaning.
2. Keep the interior clean. Wipe spills and splatters from the oven walls with a damp cloth. A mild detergent may be used if the oven is heavily soiled. Avoid spray cleaners and harsh cleaning products, as these may stain, streak or dull the door surface.
3. Clean the exterior with a damp cloth. Do not allow water to seep into the ventilation openings.
4. Wipe the door, window (both sides), door seals and surrounding areas regularly with a damp cloth to remove spills and splatters. Do not use abrasive cleaners.
5. Do not use a steam cleaner.
6. Do not allow the control panel to get wet. Clean with a soft, damp cloth. When cleaning the control panel, leave the oven door open to prevent the oven from turning on accidentally.
7. If steam accumulates inside or around the outside of the oven door, wipe with a soft cloth. This is normal and may occur in high-humidity conditions.
8. Remove the glass tray for cleaning as needed. Wash in warm soapy water or in a dishwasher.
9. Clean the roller ring and oven floor regularly to prevent excessive noise. Wipe the oven floor with a mild detergent, and wash the roller ring in warm soapy water or in a dishwasher. When replacing the roller ring, ensure it is seated correctly.
10. To remove odours, place a cup of water mixed with the juice and skin of one lemon

Information

in a microwave-safe bowl and heat for 5 minutes. Wipe thoroughly and dry with a soft cloth.

11. If the oven light needs replacing, contact a dealer or service centre.
12. Clean the oven regularly and remove any food deposits. Failure to keep the oven clean may cause surface deterioration, which can shorten the life of the appliance and create a safety hazard.
13. Do not dispose of this appliance in the domestic waste. Take it to your local designated disposal or recycling centre.

Precautions: Microwave Energy Exposure

1. Do not operate this oven with the door open. Open-door operation can result in harmful exposure to microwave energy. Do not tamper with the safety interlocks.
2. Do not place any object between the oven front and the door, or allow residue to accumulate on sealing surfaces.
3. Do not operate the oven if it is damaged. Ensure the door closes properly and that there is no damage to: the door (bent); hinges and latches (broken or loose); or door seals and sealing surfaces. The oven must only be adjusted or repaired by qualified service personnel.

Safety Instructions

When using this appliance, basic safety precautions should be followed, including the following.

WARNING: To reduce the risk of burns, electric shock, fire, injury or exposure to excessive microwave energy:

Read all instructions before use and retain for

future reference.

Use this appliance only for its intended purpose as described in this manual. Do not use corrosive chemicals or vapours in this appliance. This oven is designed to heat, cook or dry food only. It is not suitable for industrial or laboratory use.

Do not operate the oven when empty.

Do not use this appliance if the cord or plug is damaged, if it is not working properly, or if it has been damaged or dropped. If the supply cord is damaged, it must be replaced by the manufacturer, service agent or a similarly qualified person to avoid a hazard.

WARNING: Only allow children to use the oven unsupervised once adequate instruction has been given, so that the child can use the oven safely and understands the hazards of improper use.

To reduce the risk of fire in the oven cavity:

- When heating food in plastic or paper containers, check the oven frequently for signs of ignition.
- Remove wire twist-ties from paper or plastic bags before placing in the oven.
- If smoke is observed, switch off or unplug the appliance and keep the door closed to stifle any flames.
- Do not use the cavity for storage. Do not leave paper products, cooking utensils or food in the cavity when not in use.
- The microwave oven is intended for heating food and beverages only. Drying clothing or heating warming pads, slippers, sponges, damp cloths and similar items may cause injury, ignition or fire.

WARNING: Do not heat liquids or food in sealed containers — they are liable to explode. Microwave heating of beverages can cause delayed eruptive boiling. Take care when

Information

handling the container.

Do not fry food in the oven. Hot oil can damage oven parts and utensils and may cause skin burns.

Do not heat eggs in their shell or whole hard-boiled eggs in the microwave — they may explode even after heating has ended.

Pierce foods with heavy skins — such as potatoes, whole squashes, apples and chestnuts — before cooking.

The contents of feeding bottles and baby food jars should be stirred or shaken and the temperature checked before serving, to avoid burns.

Cooking utensils may become hot due to heat transferred from the food. Use oven gloves where necessary.

Check that utensils are suitable for use in a microwave oven before use.

WARNING: It is hazardous for anyone other than a trained engineer to carry out any service or repair that involves removing a cover which protects against microwave energy exposure.

This microwave complies with EN 55011/ CISPR 11, Class B Group 2 classification. It is suitable for use in residential environments and in establishments connected directly to a low-voltage public power supply network.

Not intended for use by persons (including children) with reduced physical, sensory or mental capabilities, or lack of experience and knowledge, unless supervised or instructed by a person responsible for their safety.

Children should be supervised to ensure they do not play with the appliance.

The microwave oven is for freestanding use only.

WARNING: Do not install the oven over a range cooker or other heat-producing appliance. Doing so may cause damage and will void the warranty.

The microwave oven must not be placed inside a cabinet.

The door and outer surfaces may become hot during operation.

Accessible parts may become hot during use. Keep young children away.

Take care to avoid touching heating elements inside the oven.

Do not place this appliance against a wall — ensure adequate clearance on all sides for ventilation.

WARNING: If the door or door seals are damaged, the oven must not be used until repaired by a competent person.

This appliance is not intended to be operated by means of an external timer or separate remote-control system.

For household use only — not for commercial use.

Never remove the distance holder on the back or sides of the oven, as it maintains the minimum clearance required for air circulation.

Secure the turntable before moving the appliance to prevent damage.

Caution: Repair or maintenance by anyone other than a qualified specialist is dangerous, as it requires removal of the cover that protects against microwave radiation. This includes changing the power cord. Send the appliance to a service centre in such cases.

The microwave oven is intended for defrosting, cooking and steaming food only.

Use oven gloves when removing heated food.

Caution: Steam will escape when opening lids or removing wrapping foil.

This appliance can be used by children aged 8 and above and by persons with reduced physical, sensory or mental capabilities, provided they have been given appropriate supervision or instruction and understand the hazards involved. Cleaning and user maintenance must not be carried out by

Information

children under 8 years of age.

If smoke is emitted, switch off or unplug the appliance and keep the door closed to stifle any flames.

Microwave Cooking Principles

1. Arrange food carefully. Place the thickest areas towards the outside of the dish.
2. Watch cooking times. Cook for the shortest time indicated and add more as needed — severely overcooked food can smoke or ignite.
3. Cover foods during cooking to prevent spattering and help food cook evenly.
4. Turn food over once during cooking to speed up heating — particularly chicken, burgers and large items such as joints, which must be turned at least once.
5. Rearrange foods such as meatballs halfway through cooking, moving them from top to bottom and from the centre of the dish to the outside.

Grounding Instructions

This appliance must be earthed. It is fitted with a cord containing an earth wire and earth plug, which must be plugged into a properly installed and earthed wall socket. In the event of an electrical short circuit, earthing reduces the risk of electric shock by providing an escape path for the current. It is recommended that a separate circuit serving only the oven be used. Using a high voltage supply is dangerous and may result in fire or damage to the oven.

WARNING: Improper use of the earth plug can result in a risk of electric shock.

Note:

1. If you have any questions about earthing or electrical connections, consult a qualified

electrician.

2. Neither the manufacturer nor the dealer accepts liability for damage to the oven or personal injury resulting from failure to observe the electrical connection procedures.

The wires in this cable are colour-coded as follows:

Green and Yellow = Earth
Blue = Neutral
Brown = Live

Radio Interference

Operation of the microwave oven may cause interference to your radio, TV or similar equipment. If interference occurs, it may be reduced or eliminated by:

1. Cleaning the door and sealing surfaces of the oven.
2. Reorientating the receiving aerial of the radio or television.
3. Repositioning the microwave oven relative to the receiver.
4. Moving the microwave oven away from the receiver.
5. Plugging the microwave oven into a different socket so that the oven and receiver are on different branch circuits.

Technical Specifications

Rated voltage: 230–240V, 50Hz

Rated power input: 1100W

Rated power output: 700W

Rated microwave frequency: 2450MHz

Usage & Safety



Please read all instructions carefully before use and retain for future reference.



CAUTION: Hot surfaces.



Do not use outdoors.



Do not cover.

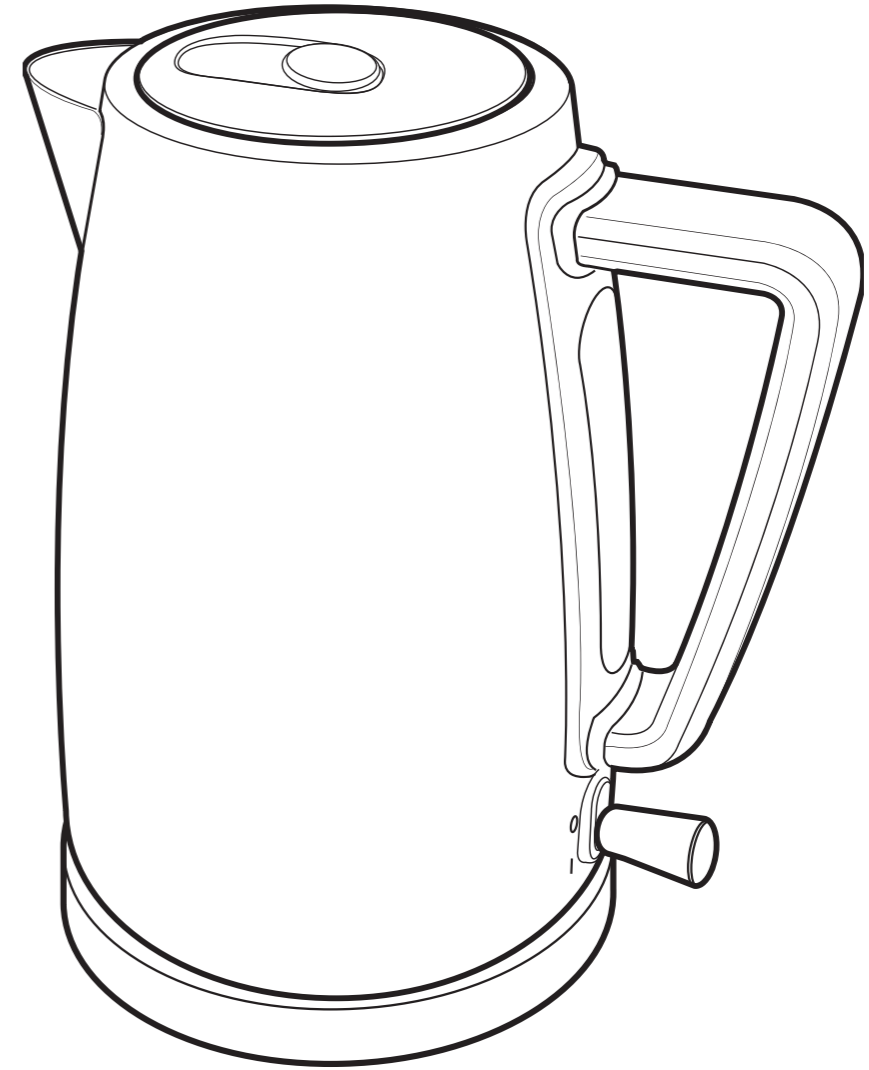

CREAM FIKA KETTLE

Product Instructions

Product No. 2000324

Components

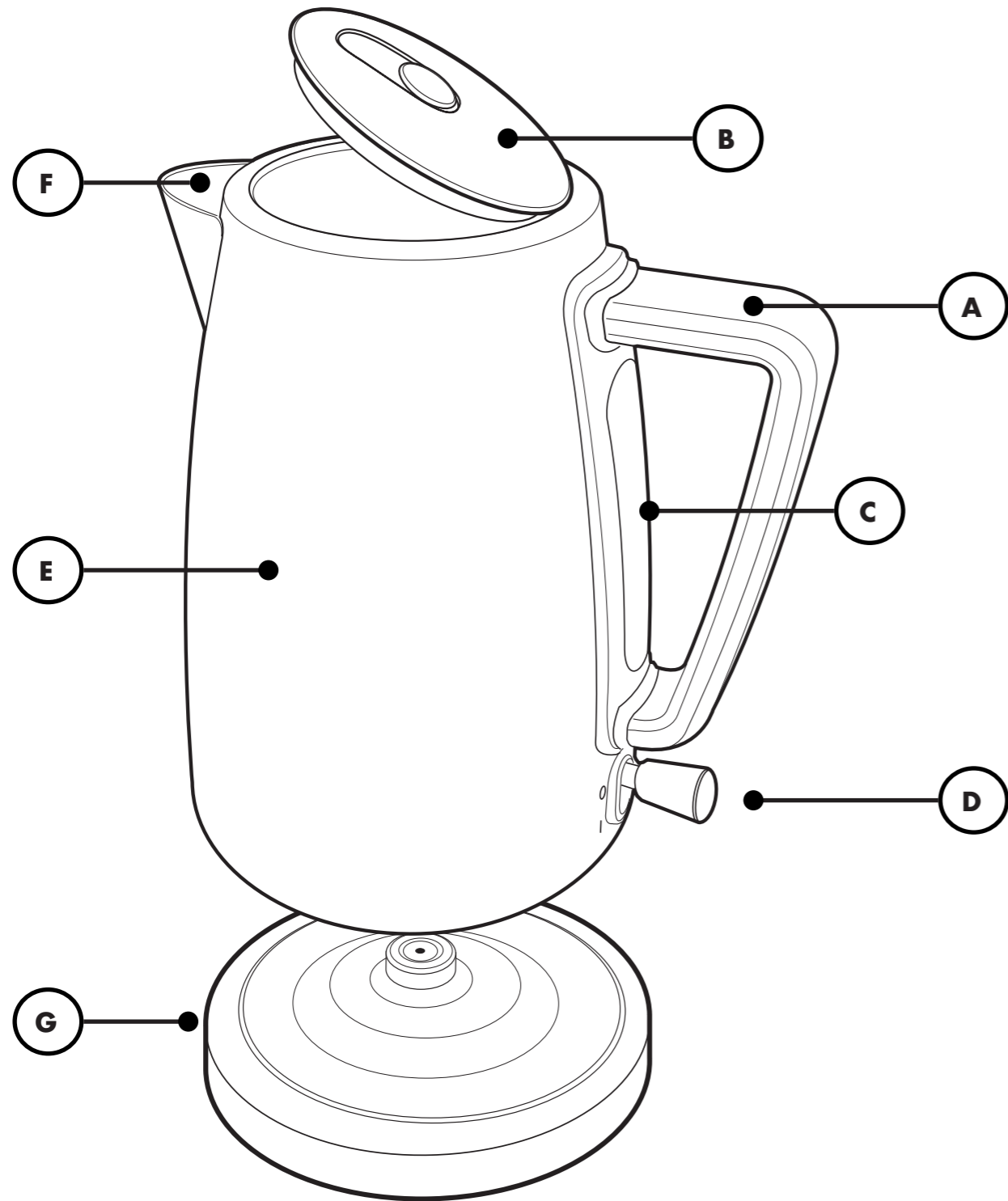

- A. Handle
- B. Lid
- C. Water Gauge
- D. Power Button

- E. Body
- F. Spout & Filter
- G. Power Base

Before First Use

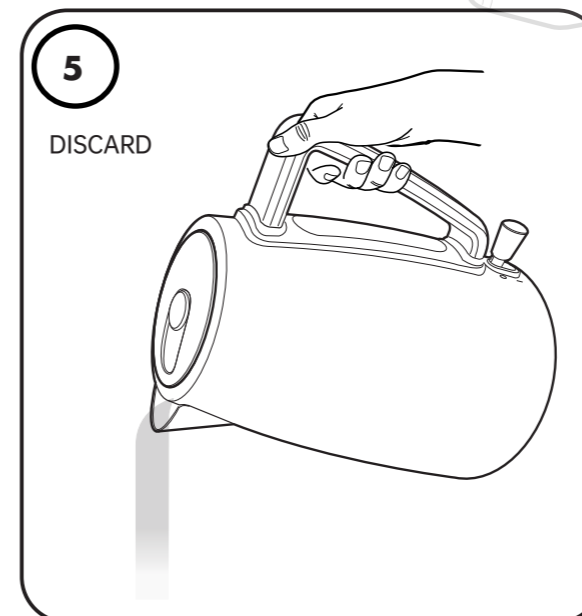
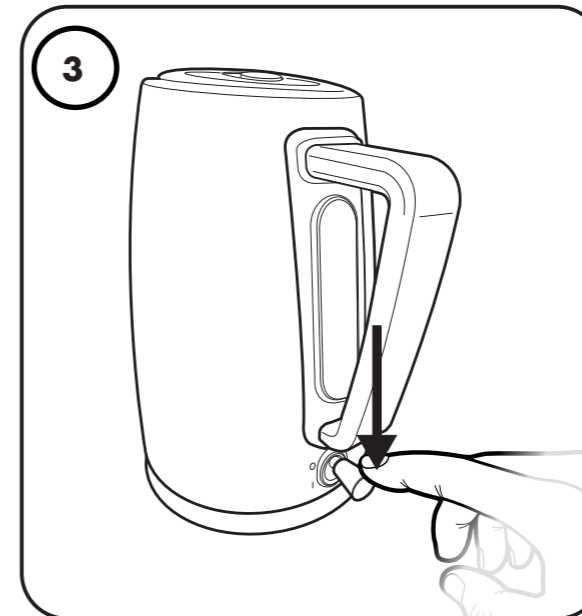
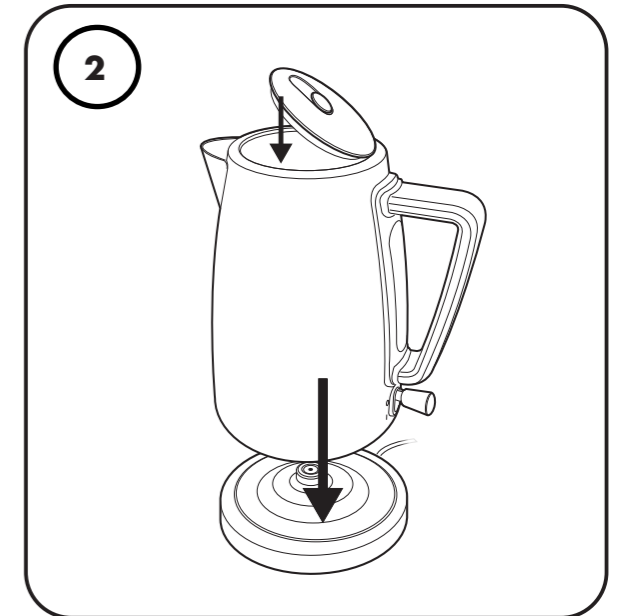
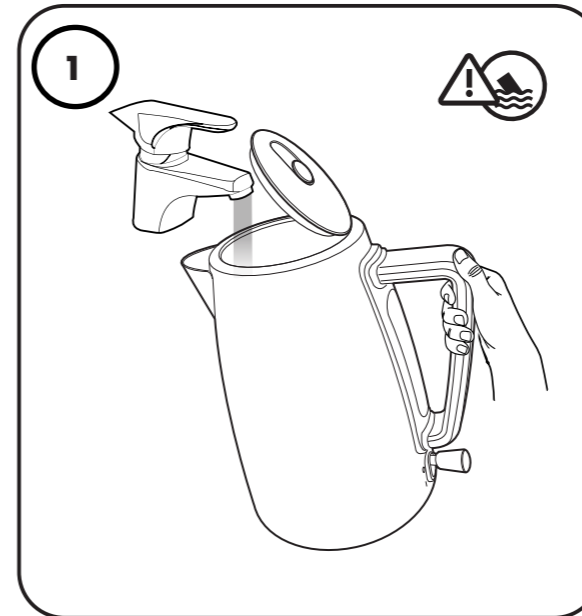

Maintenance

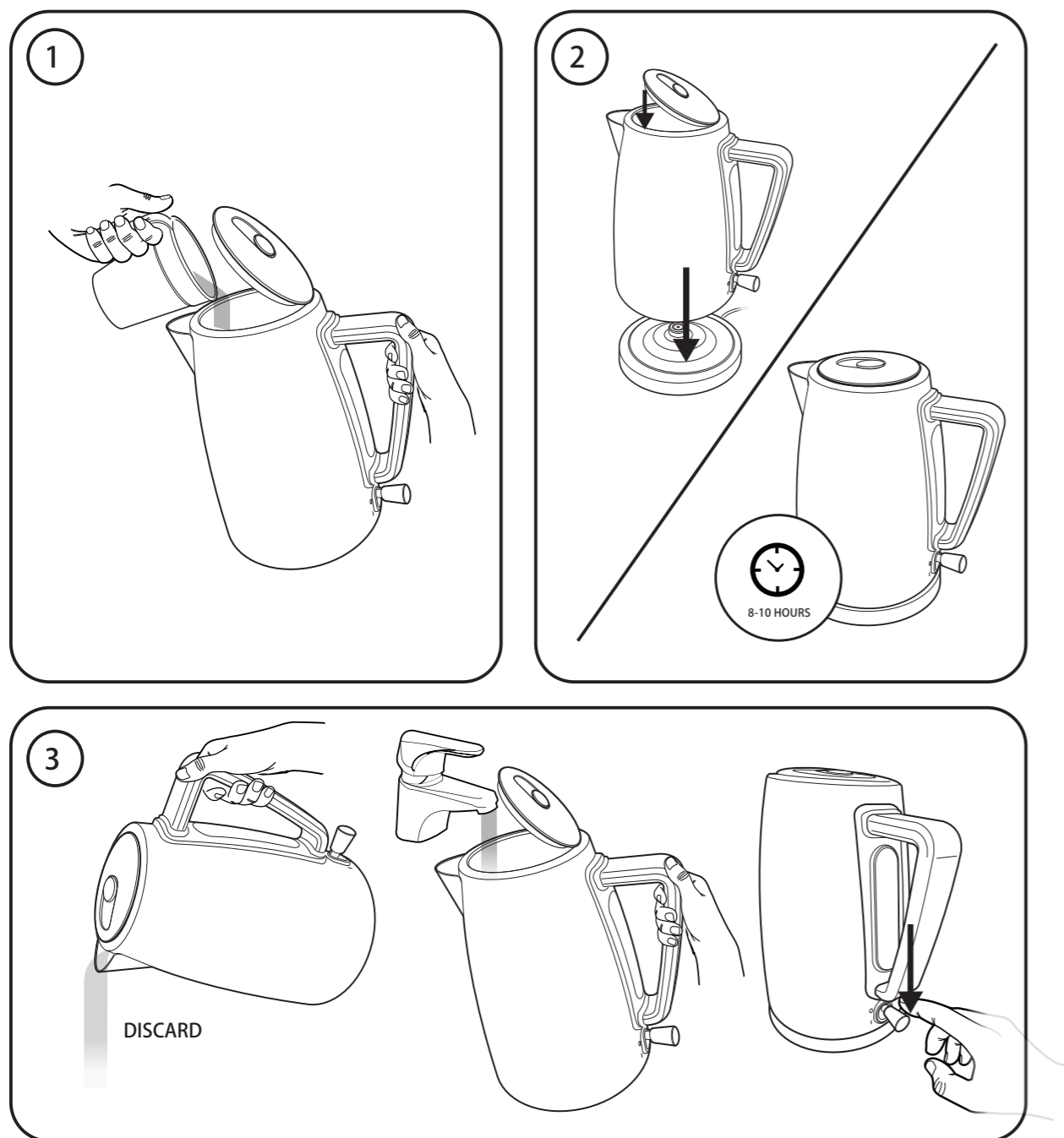

To remove build up of mineral deposits, fill the Kettle with 1 cup of white vinegar. Leave overnight (**DO NOT BOIL**).

Discard and fill with clean cold water before boiling and discarding. Repeat the filling and boiling until the odour of vinegar has been flushed away.

Information

Important Safety Notice

This product is not suitable for use by children or by individuals with physical, sensory, or mental impairments that may limit their ability to operate the equipment safely, unless they have been given supervision or instruction concerning the safe use of the product by a person responsible for their safety.

Improper use may result in serious injury. Always ensure the operator is capable of understanding and following all safety instructions provided in this manual.

Surfaces become very hot during use.

General Safety

Do not allow to be used as a toy. Children should be supervised to ensure they do not play with the appliance. If the appliance is not functioning properly, has been dropped, damaged, left outdoors or immersed in liquid, do not use — contact customer services. Do not use if any parts appear to be faulty, missing or damaged. Ensure all parts are securely attached before use.

Cables and Plugs

Check that your electricity supply matches the rating plate. The socket outlet should preferably be protected by a Residual Current Device (RCD). Do not use with a damaged cable or plug. If the supply cable is damaged, it must be replaced by a qualified engineer or authorised service agent. Extension cables are not recommended. Do not handle the plug or appliance with wet hands. Keep the cable away from heated surfaces. Do not let the cable hang over the edge of a worktop

where it could be pulled by children or pets. Do not pull the cable around sharp edges or corners. Do not leave unattended when plugged in. Unplug when not in use. Turn off all controls before unplugging. To unplug, grasp the plug, not the cable. Always unplug before performing maintenance or changing accessories. Store the cable safely to prevent hazards.

Risk of Personal Injury

Always place the appliance away from the edge of the worktop, on a firm, flat, heat-resistant surface with sufficient space on all sides. Do not insert objects into openings or cover the appliance. Do not place cardboard, plastic or paper inside or on the appliance. Do not use near combustible surfaces or heat sources. Take care not to touch surfaces that may be hot during or after use. Never operate when empty. Do not overfill. When using for the first time, the appliance may emit a smell or vapour — this will dissipate after a few uses. Do not lift or move the appliance while in use. Switch off and unplug before changing accessories or cleaning. Use only as described in this manual with DOMU Brands recommended attachments.

Cleaning and Maintenance

Never soak or immerse electrical or heating components. Hand washing recommended — soak in warm soapy water and wipe with a soft sponge. For stubborn stains, use a non-abrasive cleaning brush. Do not use abrasive or harsh cleaning products or metal scouring pads. Never wash electrical or heating components in a dishwasher.

Maintenance

Thermal Cut-Out

This appliance has a thermal cut-out switch. If the appliance overheats, the thermal cut-out will activate and shut it down. Unplug and allow to cool for 30 minutes before re-use.

Operation

1. Do not touch the exterior surfaces during operation — they become very hot.
2. Check the water gauge regularly to ensure the water level does not fall below the minimum marker.
3. Do not operate with the water level above the maximum.
4. Do not operate without water or with very little water, as this can seriously damage the heating element.
5. Do not open the lid immediately after boiling — steam will escape and may cause scalding.
6. Once finished, switch off, unplug and allow to cool completely before cleaning.

Technical Specification

Rated voltage: 220–240V
Rated power: 2500–3000W
Rated frequency: 50/60Hz

Usage & Safety



Please read all instructions carefully before use and retain for future reference.



CAUTION: Hot surfaces.



Do not immerse in water.

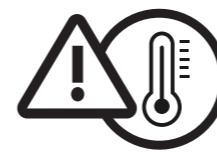

This appliance has a thermal cut-out switch. If the appliance overheats, the thermal cut-out will activate and shut it down. Unplug from the mains and allow to cool for 30 minutes before re-use.



CAUTION: Boiling water.

CREAM FIKA 2 SLICE TOASTER

Product Instructions

Product No. 2000324

vonshef

Components

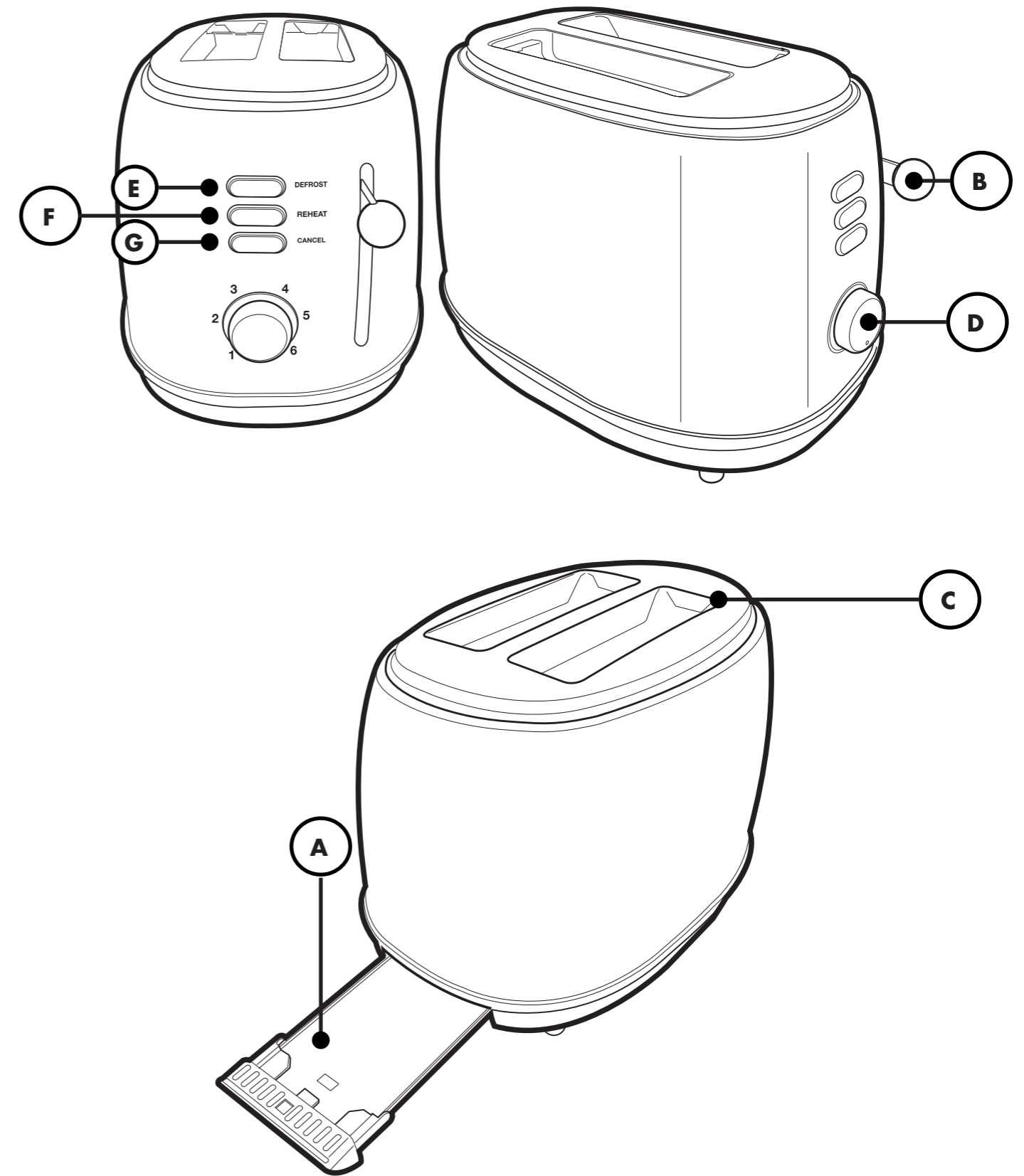

- A. Crumb Tray.
- B. Toasting Lever
- C. Toasting Slots.
- D. Browning Dial.
- E. Defrost Button.
- F. Reheat Button.
- G. Stop Button.

Operation

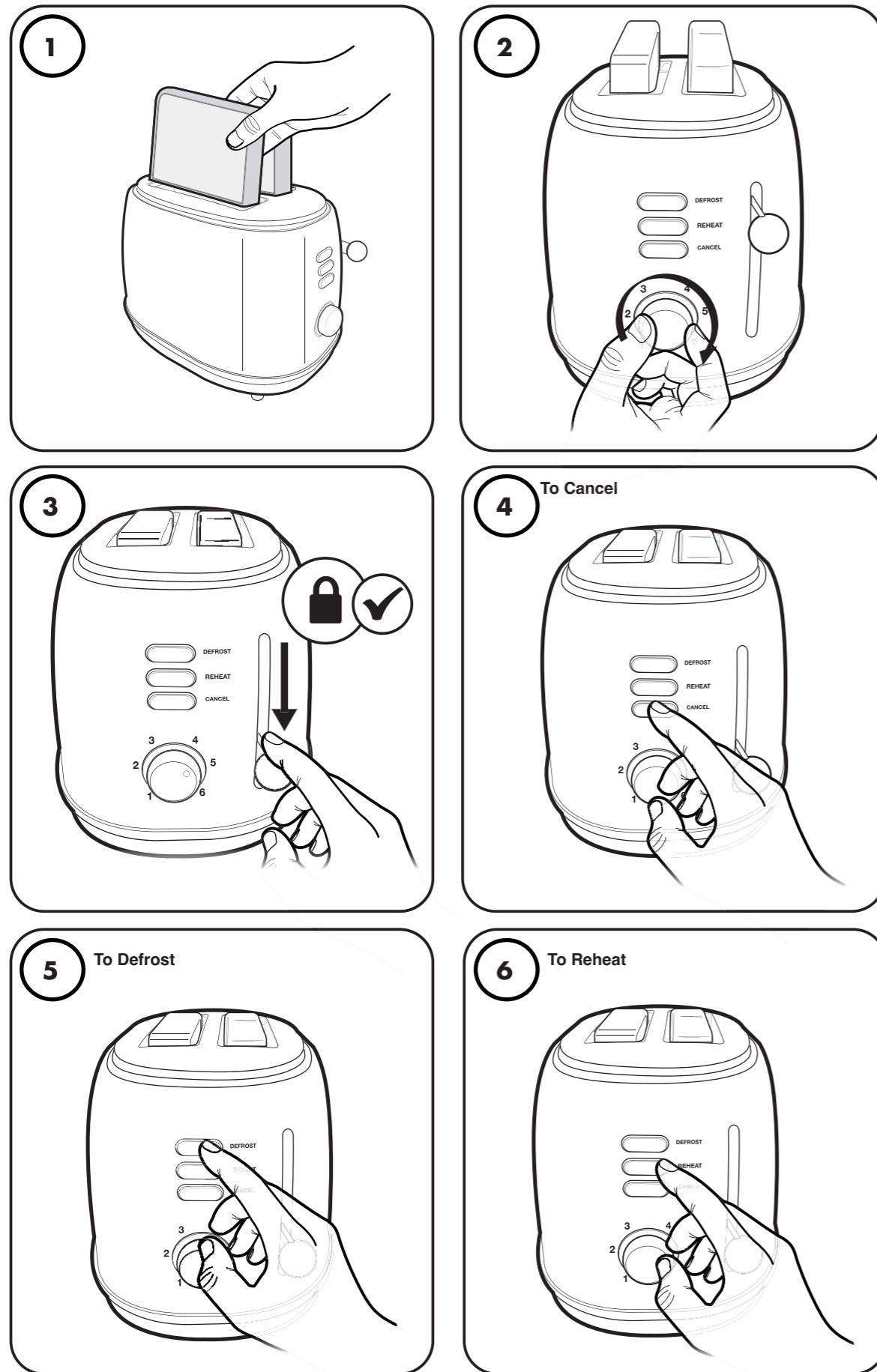

Before First Use

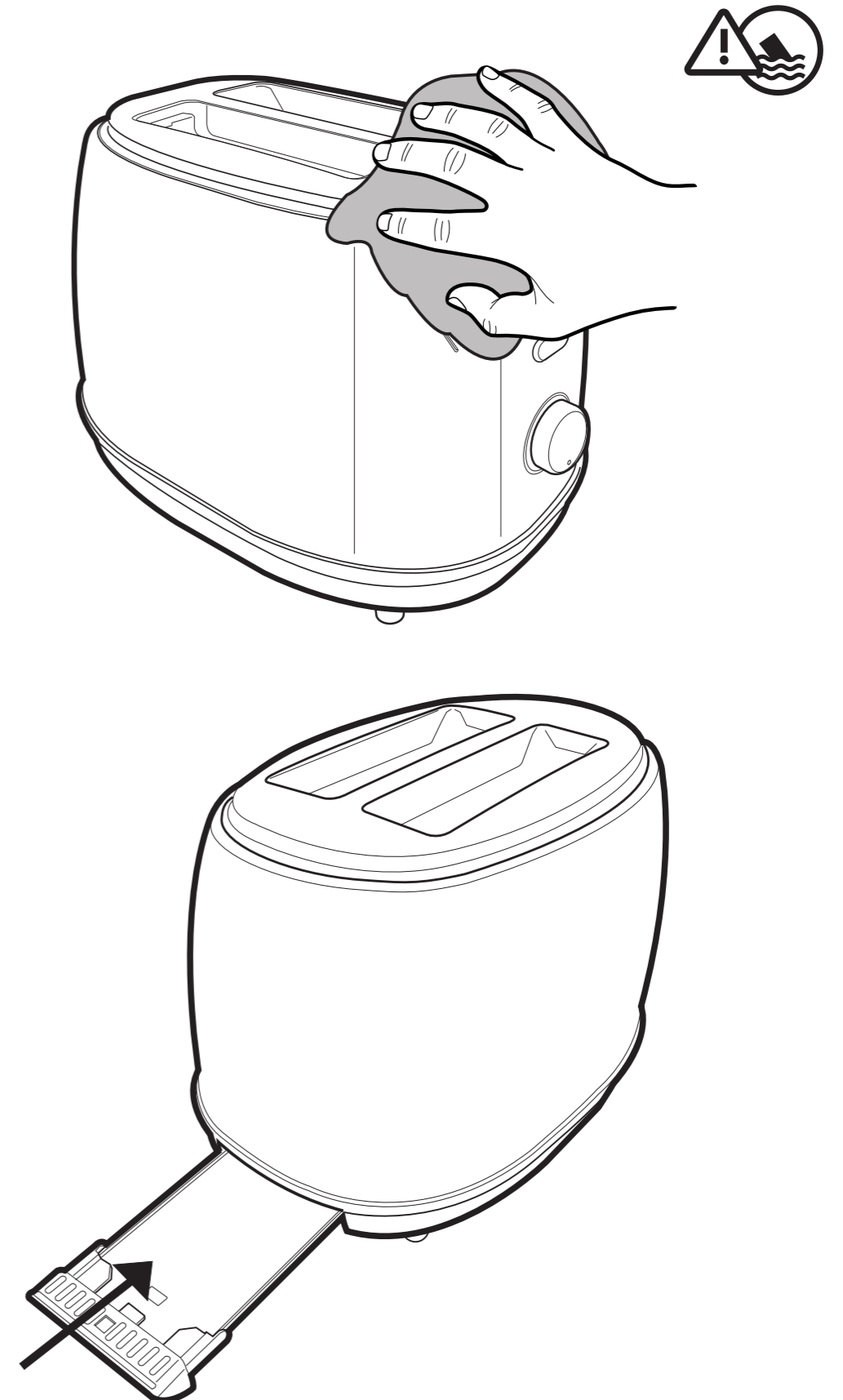

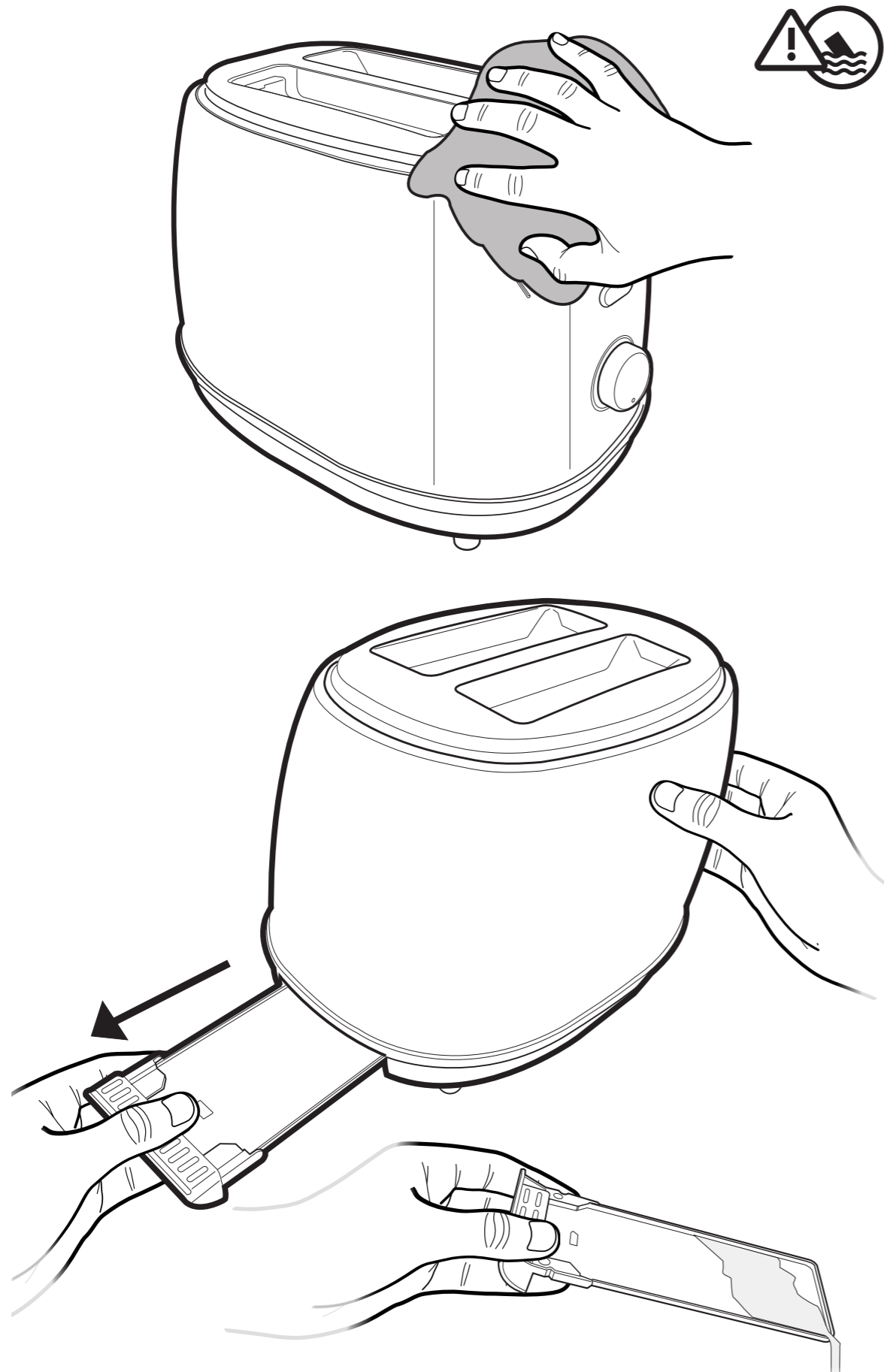

Important Safety Notice

This product is not suitable for use by children or by individuals with physical, sensory, or mental impairments that may limit their ability to operate the equipment safely, unless they have been given supervision or instruction concerning the safe use of the product by a person responsible for their safety.

Improper use may result in serious injury. Always ensure the operator is capable of understanding and following all safety instructions provided in this manual.

Surfaces become very hot during use.

General Safety

Do not allow to be used as a toy. Children should be supervised to ensure they do not play with the appliance. If the appliance is not functioning properly, has been dropped, damaged, left outdoors or immersed in liquid, do not use — contact customer services. Do not use if any parts appear to be faulty, missing or damaged. Ensure all parts are securely attached before use.

Cables and Plugs

Check that your electricity supply matches the rating plate. The socket outlet should preferably be protected by a Residual Current Device (RCD). Do not use with a damaged cable or plug. If the supply cable is damaged, it must be replaced by a qualified engineer or authorised service agent. Extension cables are not recommended. Do not handle the plug or appliance with wet hands. Keep the cable away from heated surfaces. Do not let the cable hang over the edge of a worktop

where it could be pulled by children or pets. Do not pull the cable around sharp edges or corners. Do not leave unattended when plugged in. Unplug when not in use. Turn off all controls before unplugging. To unplug, grasp the plug, not the cable. Always unplug before performing maintenance or changing accessories. Store the cable safely to prevent hazards.

Risk of Personal Injury

Always place the appliance away from the edge of the worktop, on a firm, flat, heat-resistant surface with sufficient space on all sides. Do not insert objects into openings or cover the appliance. Do not place cardboard, plastic or paper inside or on the appliance. Do not use near combustible surfaces or heat sources. Take care not to touch surfaces that may be hot during or after use. Never operate when empty. Do not overfill. When using for the first time, the appliance may emit a smell or vapour — this will dissipate after a few uses. Do not lift or move the appliance while in use. Switch off and unplug before changing accessories or cleaning. Use only as described in this manual with DOMU Brands recommended attachments.

Cleaning and Maintenance

Never soak or immerse electrical or heating components. Hand washing recommended — soak in warm soapy water and wipe with a soft sponge. For stubborn stains, use a non-abrasive cleaning brush. Do not use abrasive or harsh cleaning products or metal scouring pads. Never wash electrical or heating components in a dishwasher.

Information

Operation

1. Insert bread into the toasting slots.
2. Select a browning level using the browning dial (1–6).
3. Push down the toasting lever. The lever will pop up automatically when toasting is complete.
4. To defrost: press the Defrost button, then push down the toasting lever.
5. To reheat: press the Reheat button, then push down the toasting lever.
6. To cancel at any time: press the Stop/Cancel button.

Cleaning

1. Ensure the appliance is switched off and unplugged before cleaning.
2. Wipe the exterior with a damp cloth — do not immerse in water.
3. Remove the crumb tray, empty it and wash in warm soapy water. Allow to dry fully before replacing.

Technical specification

Rated voltage: 220–240V
Rated power: 850W
Rated frequency: 50/60Hz

Usage & Safety



Please read all instructions carefully before use and retain for future reference.



CAUTION: Hot surfaces.



Do not immerse in water



Do not cover.

Information

Customer Service

If you are having difficulty using this product and require support, please contact support@vonhaus.com

Warranty

To register your product and find out if you qualify for a free extended warranty please go to www.vonhaus.com/warranty

Please retain a proof of purchase receipt or statement as proof of the purchase date.

The warranty only applies if the product is used solely in the manner indicated in the warnings page of this manual, and all other instructions have been followed accurately.

Any abuse of the product or the manner in which it is used will invalidate the warranty.

Returns

Returned goods will not be accepted unless re-packaged in its original packaging and accompanied by a relevant and completed returns form. This does not affect your statutory rights.

No rights are given under this warranty to a person acquiring the appliance second-hand or for commercial or communal use.

Copyright

All material in this instruction manual are copyrighted by DOMU Brands.

Any unauthorised use may violate worldwide copyright, trademark, and other laws.

Thank You

Thank you for purchasing your product/appliance.

Should you require assistance with your purchase, please contact us at support@vonhaus.com

Vonhaus is a registered trademark of DOMU Brands Ltd.

Made in China for DOMU Brands Ltd.
Unit 30, Stakehill Industrial Estate
Middleton, Manchester, M24 2RW

EU Authorised Representative

Authorised Representative Service
77 Camden Street Lower
Dublin, D02 XE80
Ireland

Let's get started!

Visit our product hub for useful tips and tricks on getting the most out of your new product.

SCAN ME

