

2515028



Please read all instructions carefully before use and retain for future reference.

Veuillez lire attentivement ces instructions avant utilisation et conservez-les pour pouvoir les consulter à l'avenir.

Bitte lesen Sie die Anleitung sorgfältig und bewahren Sie sie als Referenz auf.

Leed todas las instrucciones detenidamente antes de usar y retened para futuras consultas.

Si prega di leggere attentamente tutte le istruzioni prima dell'uso e conservarle per una futura consultazione.



Maximum load capacity: 350kg/771lbs.



Do not climb on
Ne grimpez pas dessus
Steigen Sie nicht auf
No os subais en el producto
Non salirci sopra



Do not jump on
Ne pas sauter sur
Spring nicht drauf
No saltar en
Non saltare



Do not use to carry children or animals
Ne pas utiliser pour transporter des enfants ou des animaux
Nicht zum Tragen von Kindern oder Tieren verwenden
No utilizar para transportar niños o animales.
Non utilizzare per trasportare bambini o animali



Do not use to carry flammable or abrasive chemicals.
Ne pas utiliser pour transporter des produits chimiques inflammables ou abrasifs.
Nicht zum Tragen von brennbaren oder scheuernden Chemikalien verwenden.
No utilizar para transportar productos químicos inflamables o abrasivos.
Non utilizzare per trasportare sostanze chimiche infiammabili o abrasive.



Do not modify
Ne pas modifier
Nicht modifizieren
No modificar
Non modificare



Distribute load evenly
Répartir la charge uniformément
Last gleichmäßig verteilen
Distribuir la carga de manera uniforme
Distribuire uniformemente il carico



EN

INTENDED USE This product is not intended for indoor use. This product is not intended as a climbing structure and it is not a toy. Children should be supervised to ensure that they do not play with the product.

BEFORE FIRST USE

Locate the product in a suitable area where it will not create an obstruction. Locate away from sources of combustion. Before first use, ensure you check that the tyre pressure is at 30 PSI (maximum).

CAUTION: Do not inflate the tyres to more than 30 PSI. Do not use the Dump Truck on surfaces that can cause damage to the pneumatic tyres, or transport objects that may damage the tyres. Always check for damaged or worn out parts before using the Dump Truck. Do not use the Dump Truck if any parts are worn or broken. Seek suitable repair or replacement from a qualified person.

GENERAL SAFETY Place on solid and even ground. Only use in an upright stable position. Do not overload the product as this may result in damage to the product or personal injury. Take care during assembly, use and maintenance. Various crush and shear points are present in the turning axle and around the handles. Wear suitable safety equipment including footwear and gloves or any additional equipment recommended for the task at hand.

CLEANING & MAINTENANCE Do not clean the product with any abrasive cloths or chemicals. Solvents or detergents can cause damage to the surface. To clean, sponge down with warm water, a soft cloth and mild detergent. Ensure you have all the pieces listed. If you are missing any components, contact our customer services department at support@vonhaus.com

FR

UTILISATION PRÉVUE Ce produit n'est pas conçu pour une utilisation en intérieur. Ce produit ne doit pas être utilisé comme une échelle et ce n'est pas un jouet. Les enfants devraient toujours être supervisés pour s'assurer qu'ils ne jouent pas avec le produit.

AVANT LA PREMIÈRE UTILISATION Placez le produit dans un endroit approprié, où il ne constituera pas un obstacle. Tenez éloigné de toutes sources de combustion.

CONSIGNES GÉNÉRALES DE SÉCURITÉ Placez sur un sol solide et plat. N'utilisez qu'en position stable et verticale. Ne surchargez jamais le produit : ceci pourrait l'endommager ou entraîner des blessures.

NETTOYAGE ET ENTRETIEN Ne nettoyez pas le produit avec des chiffons ou des produits chimiques abrasifs. Les solvants ou les détergents pourraient endommager la surface. Pour nettoyer, utilisez une éponge avec de l'eau chaude, un chiffon et un détergent doux. Vérifiez que vous avez toutes les pièces listées. S'il vous manque des pièces, contactez notre département de service à la clientèle à support@vonhaus.com

DE

NUTZUNGSZWECK Dieses Produkt ist nicht für den Gebrauch in Innenräumen vorgesehen. Dieses Produkt ist nicht als Klettergerüst gedacht und es ist kein Spielzeug. Kinder sollten beaufsichtigt werden. Stellen Sie sicher, dass Kinder nicht mit dem Produkt spielen.

VOR DER ERSTEN NUTZUNG Platzieren Sie das Produkt an einem geeigneten Ort, an dem es kein Hindernis darstellt. Halten Sie es fern von Zündquellen.

ALLGEMEINE SICHERHEIT Stellen Sie das Produkt auf eine feste und ebene Fläche. Verwenden Sie es nur in aufrechter und stabiler Position. Überlasten Sie das Produkt nicht, da dies zu Schäden am Produkt oder zu Verletzungen führen kann.

REINIGUNG & PFLEGE Reinigen Sie das Produkt nicht mit Scheuertüchern oder Chemikalien. Lösungsmittel oder Reinigungsmittel können die Oberfläche beschädigen. Verwenden Sie zum Reinigen warmes Wasser, eine Schwamm und eine mildes Reinigungsmittel. Stellen Sie sicher, dass alle unten aufgeführten Komponenten enthalten sind. Sollten Teile fehlen kontaktieren Sie bitte unseren Kundendienst unter support@vonhaus.com

ES

USO PREVISTO Este producto no está destinado para uso en interiores. Este producto no pretende ser una estructura de escalada y no es un juguete.

Los niños deben ser supervisados para asegurarse de que no jueguen con el producto.

ANTES DEL PRIMER USO Ubique el producto en un área adecuada donde no creará una obstrucción. Ubíquese lejos de las fuentes de combustión.

SEGURIDAD GENERAL Colocad sobre suelo sólido y nivelado. Solo usad en posición vertical estable. No sobrecargad el producto, ya que puede dañar el producto o provocar lesiones personales.

LIMPIEZA Y MANTENIMIENTO No limpiad el producto con paños abrasivos o productos químicos. Los solventes o detergentes pueden dañar la superficie.

Para limpiar, utilizad una esponja con agua tibia, un paño y un detergente suave. Tened todas las piezas en la lista. Si le falta algún componente, póngase en contacto con nuestro departamento de atención al cliente en support@vonhaus.com

IT

USO PREVISTO Questo prodotto non è destinato per uso

interno. Questo prodotto non può essere utilizzato come struttura per arrampicarsi e non è un giocattolo. I bambini devono essere supervisionati affinché non giochino con il prodotto.

PRIMA DEL PRIMO UTILIZZO Posizionare il prodotto in un'area idonea e affinché non sia di ostacolo. Posizionare lontano da fonti di combustione.

SICUREZZA GENERALE Posizionare su una superficie solida e in piano. Usare solo in posizione eretta e stabile. Non sovraccaricare il prodotto poiché ciò può danneggiare il prodotto o provocare lesioni personali.

PULIZIA E MANUTENZIONE Non pulire il prodotto con alcun panno abrasivo o agente chimico. I solventi o i detergenti possono provocare danni alla superficie.

Per pulire, insaponare con dell'acqua tiepida, un panno morbido e del detersivo delicato. Accertarsi di avere tutti i pezzi elencati. In caso di componenti mancanti, contattare il nostro servizio clienti su

support@vonhaus.com

TOOLS REQUIRED*

NOT SUPPLIED



Adjustable Wrench

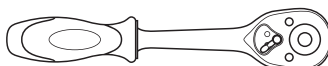

Ratchet Wrench with 13mm Socket



Flat screwdriver



Two person assembly advised

COMPONENTS



A: M8*20 Bolt
Washer/Nylock Nut (**x13**)



B: M6*25 Bolt
Washer/Nylock Nut (**x1**)

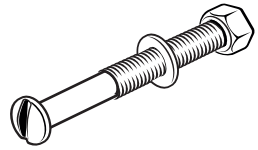

C: M8*60 Bolt
Washer/Nylock Nut (**x1**)



D: Split Washers
(**x4**)



E: Dome Lock-nuts
(**x4**)

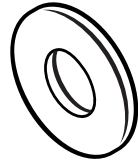

F: M12 Washers
(**x4**)

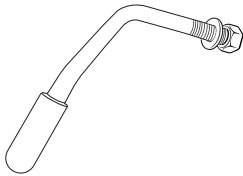

G: Locking
Handles (**x4**)

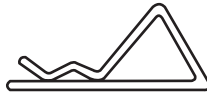

H: R-Pins
(**x8**)



I: Cotter Pin
(**x1**)

COMPONENTS

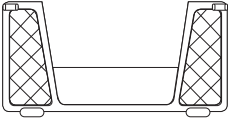

1: Front Panel

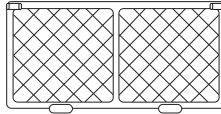

2: Rear Panel

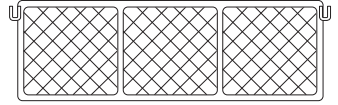

3: Side Panels
(x2)

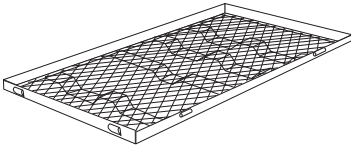

4: Base

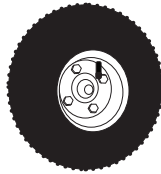

5: Pneumatic Wheels
(x4)

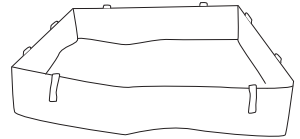

6: Heavy Duty Plastic Liner

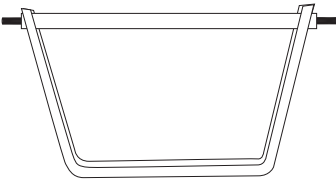

7: Rear Axle Support

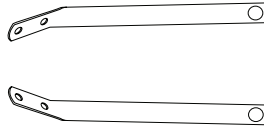

8: Axle Braces

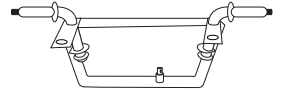

9: Front Axle Support

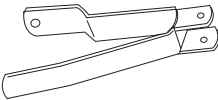

10: Centre Axle Brace

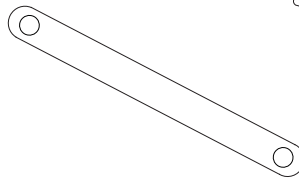

11: Front Axle Joint

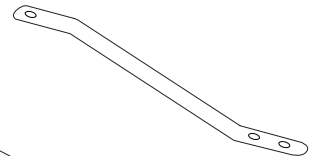

12: Steering Brace

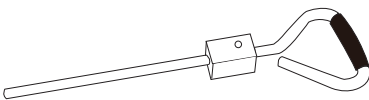

13: Steering Bar

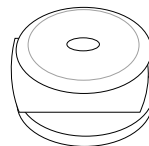

ASSEMBLY

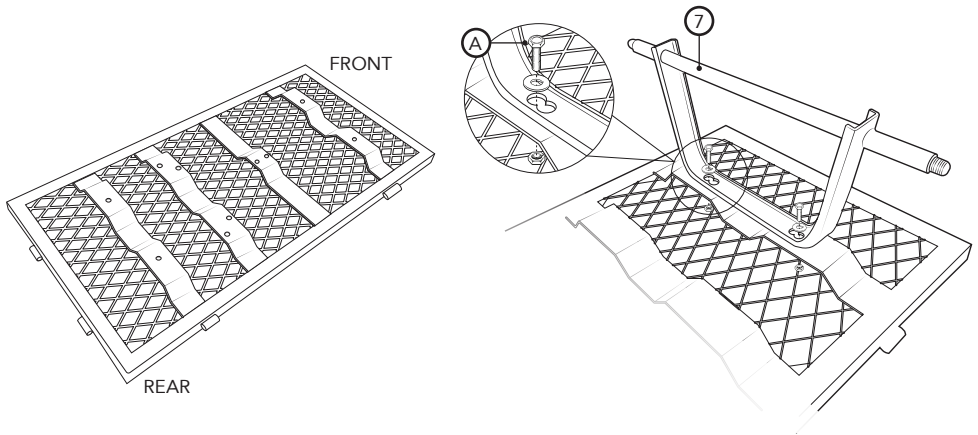

STEP 1

Take the Base (4) and place it upside down so the mesh is facing downwards.

STEP 2

Take the Rear Axle Support (7) and align the outer holes over the rear of the Base (4).

Attach by inserting 2x M8*22 Bolts (A) through the outer holes.

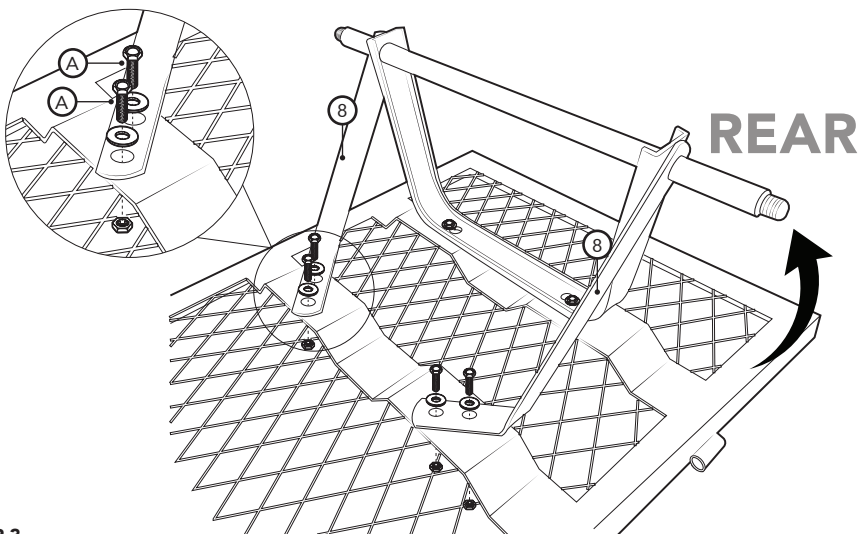

STEP 3

Place the Axle Braces (8) over the threaded ends of the Rear Axle Support (7).

Secure the Axle Braces to the Base using 4x M8*22 Bolts (A).

ASSEMBLY

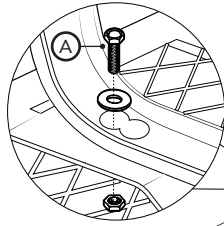

FRONT

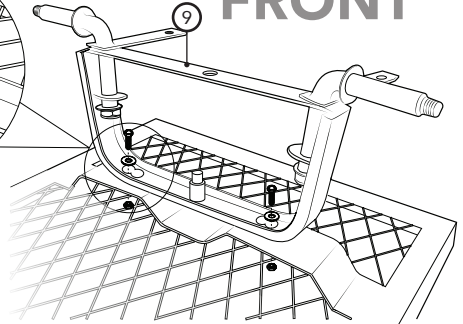

STEP 4

Move to the front of the **Base (1)** and attach the **Front Axle Support (9)**.

Secure into place using **2x M8*22 Bolts (A)** into the outer holes.

STEP 5

Take the **Front Axle Joint (11)** and secure it to the **Front Axle Support (9)**.

Secure using **2x M8*22 Bolts (A)**.

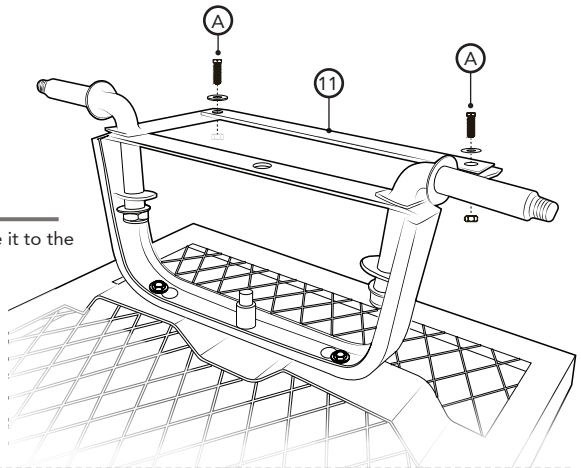

STEP 6

Take the **Centre Axle Brace (10)** place the bottom over the protruding pin and insert the **Cotter Pin (I)** through the small hole and bend out the ends to secure.

Secure the rear section to the **Front Axle Support (9)** using **1x M8*22 Bolt (A)**.

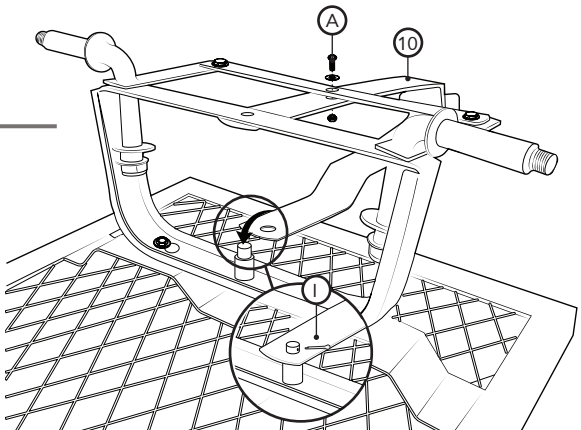

ASSEMBLY

STEP 7

Take the **Steering Brace (12)** place underneath the **Centre Axle Brace (10)** and **Front Axle Support (9)**, thread **1x M6*26 Bolt (B)** through all 3 components and secure into place.

Secure the front section of the **Steering Brace (B)** to the Base using **2x M8*22 Bolts (A)**.

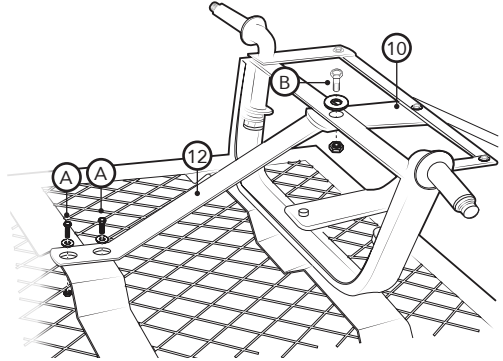

STEP 8

Attach the **Pneumatic Wheels (5)** by sliding over the Front and Rear Axle Supports and securing each one into place using a **Dome Locknut (E)**, **Split Washer (D)** and **M12 Washer (F)**. Tighten to secure.

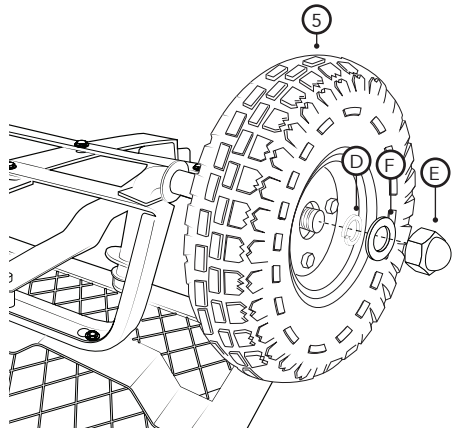

STEP 9

Insert the **Steering Bar (13)** into the **Hinge (14)**.

Place it between the holes on the **Centre Axle Brace (10)**

Align the holes up and thread **M8*65mm Bolt (C)** through the assembly and tighten to secure.

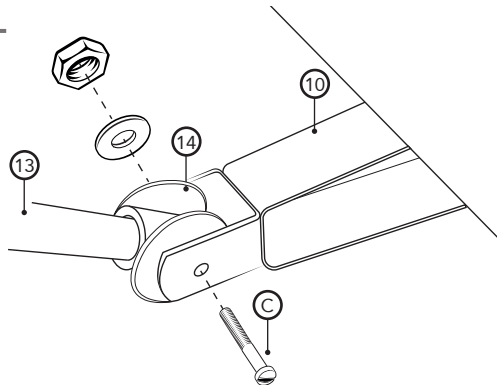

ASSEMBLY

STEP 10

Attach the **Front Panel (1)**, **Rear Panel (2)** and **2 Side Panels (3)** to the **Base (4)** by pushing the **R-Pins (H)** through the 2 hinges on the outer side of each Panel and on the Base. Repeat this for each Panel, ensuring you fit 2 to each side.

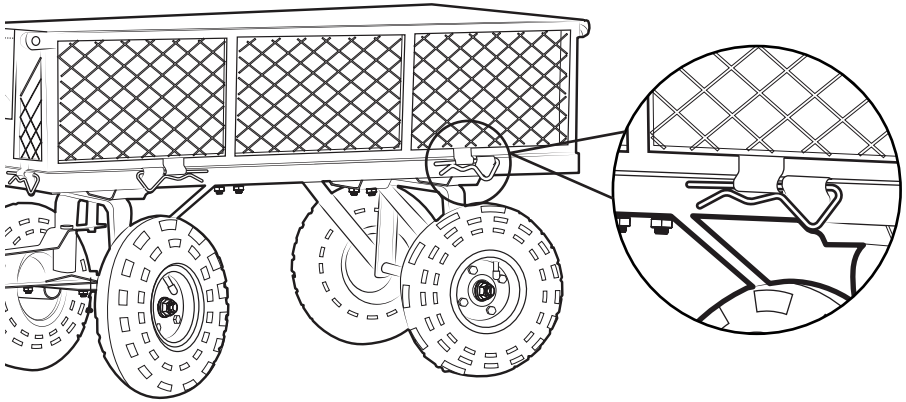

STEP 11A

Attach the **Locking Handles (G)** to the Front and Rear Panels through the C-Shaped hinges located on the top corner of each Panel.

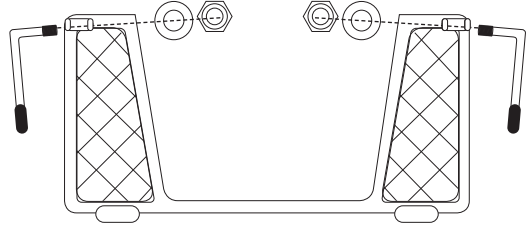

STEP 11B

Lift the Locking Handles to align with the slots on the Side Panels. Lower the Locking Handles to secure.

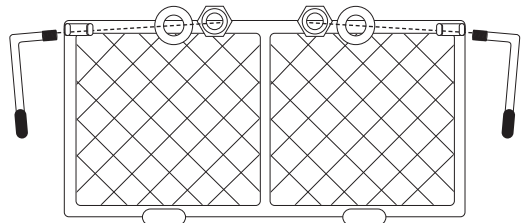

ASSEMBLY

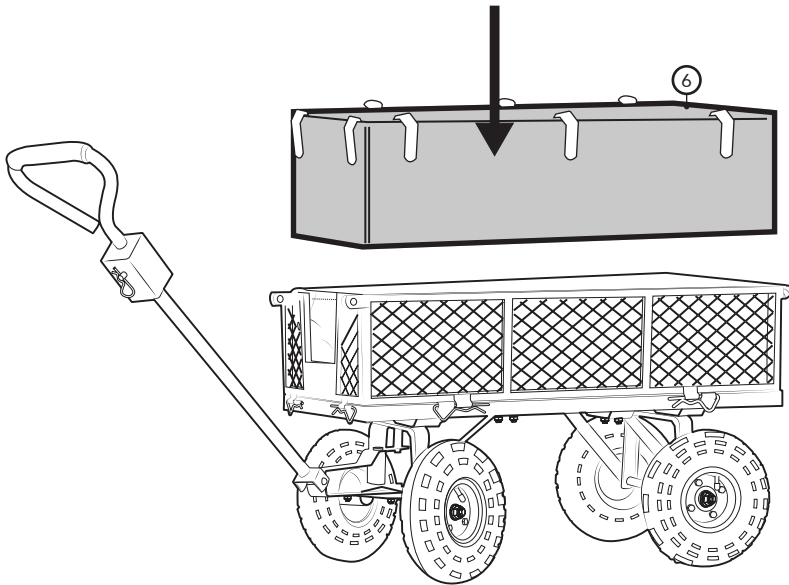



EN

DISPOSAL INFORMATION Please recycle where facilities exist. Check with your local authority for recycling advice.

CUSTOMER SERVICE If you are having difficulty using this product and require support, please contact support@vonhaus.com

WARRANTY To register your product and find out if you qualify for a free extended warranty please go to www.vonhaus.com/warranty. Please retain a proof of purchase receipt or statement as proof of the purchase date. The warranty only applies if the product is used solely in the manner indicated in the warnings page of this manual, and all other instructions have been followed accurately. Any abuse of the product or the manner in which it is used will invalidate the warranty. Returned goods will not be accepted unless re-packaged in its original packaging and accompanied by a relevant and completed returns form. This does not affect your statutory rights. No rights are given under this warranty to a person acquiring the appliance second-hand or for commercial or communal use.

COPYRIGHT All material in this instruction manual are copyrighted by DOMU Brands. Any unauthorised use may violate worldwide copyright, trademark, and other laws.

FR

INFORMATIONS RELATIVES AU RECYCLAGE Veuillez recycler là où il existe des installations adéquates. Vérifiez auprès de vos autorités locales pour obtenir des conseils sur le recyclage.

SERVICE CLIENT Si vous rencontrez des difficultés pour utiliser ce produit et avez besoin d'assistance, veuillez contacter support@vonhaus.com

GARANTIE Pour enregistrer votre produit et découvrir si vous vous qualifiez pour une extension gratuite de garantie, rendez-vous sur www.vonhaus.com/warranty. Conservez une preuve d'achat, reçu ou attestation, pour prouver la date de l'achat. La garantie ne s'applique que si le produit a été utilisé de la manière indiquée dans la section de la page des avertissements de ce manuel et que toutes les instructions ont été suivies de manière précise. Tous les abus réalisés sur le produit, dans la manière dont il a été utilisé, rendront la garantie caduque. Les marchandises renvoyées ne seront acceptées que si elles sont remballées dans leur emballage d'origine et accompagnées d'un formulaire de retour adéquat et rempli. Ceci n'affecte pas vos droits statutaires. Cette garantie n'accorde aucun droit à une personne obtenant le produit de seconde main ou à des fins d'utilisation commerciale ou communale.

DROITS D'AUTEUR Toutes les informations de ce manuel d'utilisation sont protégées par droit d'auteur par DOMU Brands. Toute utilisation non autorisée pourrait enfreindre les lois mondiales de droit d'auteur, de marque déposée ainsi que d'autres lois.

DE

ENTSORGUNG Bitte entsorgen Sie das Produkt an geeigneten Entsorgungsstellen. Fragen Sie bei Ihrer Gemeinde nach.

KUNDENSERVICE Wenn Sie Schwierigkeiten mit diesem Produkt haben und Unterstützung benötigen, wenden Sie sich bitte an support@vonhaus.com

GARANTIE Um Ihr Produkt zu registrieren und zu erfahren, ob eine kostenlose verlängerte Garantie möglich ist, gehen Sie bitte auf www.vonhaus.com/warranty. Bitte behalten Sie eine Rechnung oder den Kassenzettel als Nachweis des Einkaufsdatums auf. Die Garantie gilt nur, wenn das Produkt nur wie in dieser Anleitung beschrieben verwendet wurde und wenn alle Anweisungen befolgt wurden. Jeglicher Missbrauch des Produkts oder der Art und Weise, in der es verwendet wird, macht die Garantie ungültig. Zurückgegebene Artikel werden nur akzeptiert, wenn sie sich in der Originalverpackung befinden und wenn ein relevantes und vollständig ausgefülltes Rücksendeformular enthalten ist. Dies betrifft nicht Ihre gesetzlichen Ansprüche. Für Artikel, die gebraucht erworben wurden, oder die kommerzielle oder gemeinschaftlich genutzt werden, entstehen keinerlei Ansprüche auf Garantie.

COPYRIGHT Alle Materialien in dieser Anleitung stehen unter Copyright von DOMU Brands Ltd. Jede unautorisierte Verwendung kann das weltweite Copyright, die Handelsmarke und andere Gesetze verletzen.

ES

INFORMACION DE DESECHO Por favor, recicla en las instalaciones correspondientes. Consulta con vuestra autoridad local para obtener consejos de reciclaje.

SERVICIO AL CLIENTE Si tiene dificultades para utilizar este producto y necesita asistencia, contacte con support@vonhaus.com

GARANTÍA Para registrar vuestro producto y averiguar si califica para una garantía extendida gratuita, vaya a www.vonhaus.com/warranty. Conservad un comprobante de recibo de compra o extracto como prueba de la fecha de compra. La garantía solo se aplica si el producto se utiliza únicamente de la manera indicada en la página de advertencias de este manual, y todas las demás instrucciones se han seguido con precisión. Cualquier abuso del producto o la manera en que se use invalidará la garantía. Los productos devueltos no se aceptarán a menos que se vuelvan a empaquetar en su embalaje original y acompañados por un formulario de devolución completo y pertinente. Esto no afecta sus derechos legales. No se otorgan derechos bajo esta garantía a una persona que adquiere el aparato de segunda mano o para uso comercial o comunitario.

DERECHOS DE AUTOR Todo el material en este manual de instrucciones está protegido por DOMU Brands. Cualquier uso no autorizado puede violar los derechos de autor, marcas comerciales y otras leyes en todo el mundo.

IT

INFORMAZIONI SULLO SMALTIMENTO Si prega di riciclare nelle apposite strutture. Chiedere una consulenza alle autorità competenti per il riciclo.

SERVIZIO CLIENTI Se si riscontrano difficoltà nell'utilizzo di questo prodotto e si richiede supporto, contattare support@vonhaus.com

GARANZIA Per registrare il prodotto e capire se hai diritto all'estensione di garanzia, vai su www.vonhaus.com/warranty. Si prega di conservare la ricevuta del pagamento quale prova della data d'acquisto. La garanzia si applica solo se il prodotto viene utilizzato esclusivamente come indicato nella pagina delle Avvertenze del presente manuale e se tutte le altre informazioni vengano accuratamente seguite. Qualsiasi abuso nell'utilizzo di questo prodotto invaliderà la garanzia. I resi non saranno accettati se non riposti nella confezione originale ed accompagnati da un modulo di reso completo. Ciò non pregiudica i propri diritti obbligatori. La presente garanzia non attribuisce alcun diritto a coloro che acquistano prodotti di seconda mano o per fini commerciali o condivisi.

COPYRIGHT Tutto il materiale contenuto nel presente manuale delle istruzioni è protetto da copyright di DOMU Brands. Qualsiasi uso non autorizzato potrebbe violare il copyright a livello mondiale, marchio ed altre leggi.

THANK YOU

Thank you for purchasing your product/appliance. Should you require further assistance with your purchase, you can contact us at support@vonhaus.com

VonHaus is a registered trademark of DOMU Brands Ltd. Made in China for DOMU Brands. Unit 30, Stakehill Industrial Estate, Middleton, Manchester M24 2RW.

EU Authorised Representative: Authorised Representative Service, 77 Camden Street Lower, Dublin, D02 XE80, Ireland.

MERCI

Merci d'avoir acheté notre produit/appareil. Si vous aviez besoin d'aide suite à votre achat, vous pouvez nous contacter à support@vonhaus.com

VonHaus est une marque déposée de DOMU Brands Ltd. Fabriqué en Chine pour DOMU Brands. Unit 30, Stakehill Industrial Estate, Middleton, Manchester M24 2RW.

Représentant autorisé de l'UE: Service de Représentant Autorisé, 77 Camden Street Lower, Dublin, D02 XE80, Irlande.

VIELEN DANK

Vielen Dank, dass Sie das Produkt/Gerät gekauft haben. Sollten Sie weitere Unterstützung benötigen, können Sie uns gerne unter (email) kontaktieren support@vonhaus.com

VonHaus ist eine registrierte Handelsmarke von DOMU Brands Ltd. Hergestellt in China für DOMU Brands. Unit 30, Stakehill Industrial Estate, Middleton, Manchester M24 2RW.

EU-Autorisierter Vertreter: Bevollmächtigter Vertreterservice, 77 Camden Street Lower, Dublin, D02 XE80, Irland.

GRACIAS

Gracias por comprar vuestro producto/aparato. Si requiere asistencia con vuestra compra, podeis contactarnos a support@vonhaus.com

VonHaus es una marca registrada de DOMU Brands Ltd. Hecha en China para DOMU Brands. Unit 30, Stakehill Industrial Estate, Middleton, Manchester M24 2RW.

Representante autorizado en la UE: Servicio de Representante Autorizado, 77 Camden Street Lower, Dublin, D02 XE80, Irlanda.

GRAZIE

Grazie per aver acquistato il prodotto. Per ulteriore assistenza sul tuo acquisto, puoi contattarci all'indirizzo email support@vonhaus.com

VonHaus è un marchio registrato di DOMU Brands Ltd. Made in Cina per DOMU Brands. Unit 30, Stakehill Industrial Estate, Middleton, Manchester M24 2RW.

Rappresentante autorizzato dell'UE: Servizio di Rappresentante Autorizzato, 77 Camden Street Lower, Dublino, D02 XE80, Irlanda.

Let's get started!

Visit our product hub for useful tips and tricks on getting the most out of your new product.

SCAN ME

